

Electric actuator

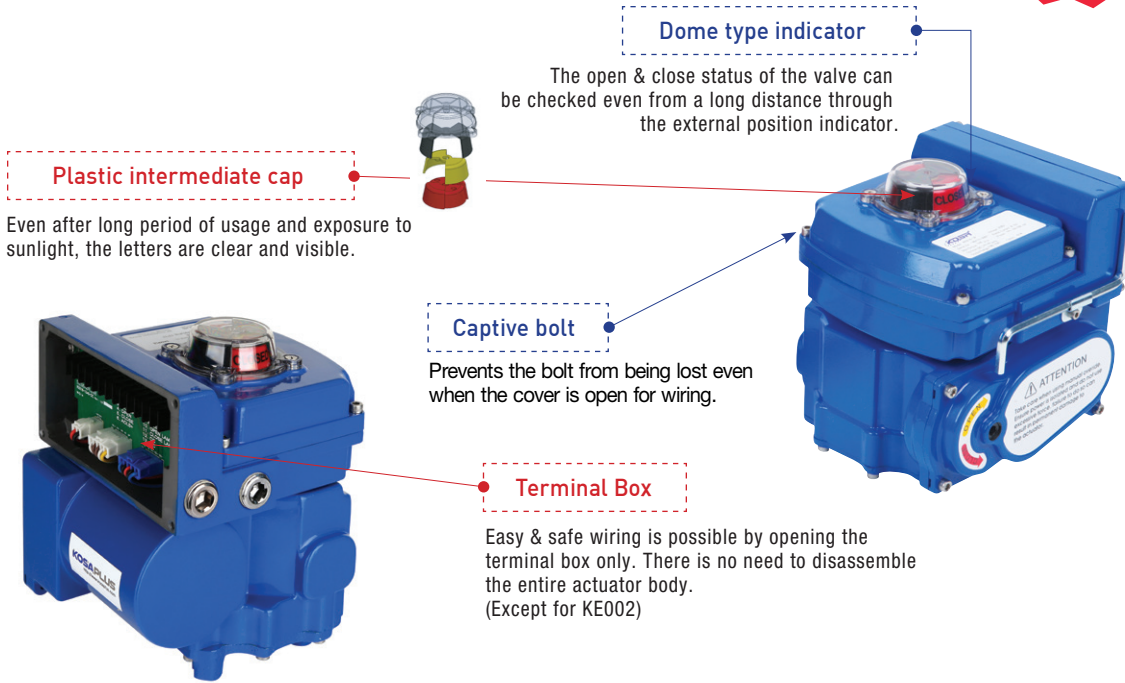

Dome type indicator

The open & close status of the valve can be checked even from a long distance through the external position indicator.

Plastic intermediate cap

Even after long period of usage and exposure to sunlight, the letters are clear and visible.

Captive bolt

Prevents the bolt from being lost even when the cover is open for wiring.

Terminal Box

Easy & safe wiring is possible by opening the terminal box only. There is no need to disassemble the entire actuator body. (Except for KE002)

► Selection guide

Valve Size		Ball Valve [2way/10K/#150]	Butterfly Valve [2way/10K/#150]
1/2"	15A	KE002	
3/4"	20A	KE004	
1"	25A		
1-1/4"	32A	KE005	
1-1/2"	40A	KE006	KE002
2"	50A	KE008	
2-1/2"	65A	KE010	KE004
3"	80A	KE016	
4"	100A	KE028	KE005/KE006
5"	125A	KE040	KE008/KE010
6"	150A	KE050/KE080	KE016
8"	200A	KE080/KE120	KE028
10"	250A		KE040/KE050
12"	300A		KE080
14"	350A		KE080/KE120
16"	400A		KE120

- Data contained in the Catalog may be subject to change without advance notice for improvement of performance & safety of product.
 - Contact us for the most recent product and technical information. Visit our website for more details : <http://www.kosaplus.com>

Contents

- Model code
- Performance Specification ISO5211&stem
- Dimension
- Wiring
- Option table Modulating Control
- DC control board 2 wire/3 wire
- Local control
- Explosion proof

► Model code

Q5N20-2AL357C14-0P

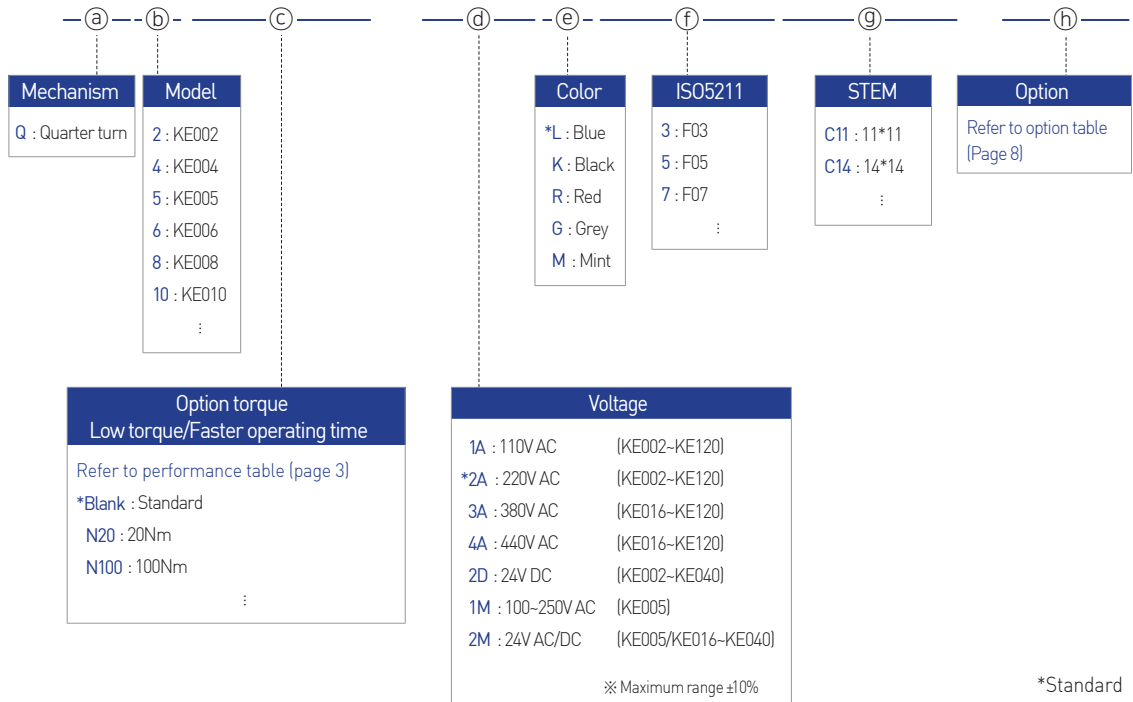

KE001

► Performance

MODEL	MAX TORQUE (Nm)	OP. TIME 50/60Hz(sec)	RATED CURRENT(A)		DUTY-CYCLE	MOTOR CLASS/OUTPUT
			AC(1PH) 50/60Hz			
			110V	220V		
KE001	8	14.5/12	0.1/0.09	0.07/0.06	40%	E/2W
KE001-4N	4	7/6	0.1/0.09	0.07/0.06	40%	E/2W



► Standard specification

MAIN POWER	110V/220V AC 1PH	CABLE ENTRIES	WIRE TYPE
DUTY CYCLE	40%	AMBIENT TEMPERATURE	-20°C~+60°C
INDICATOR	DOME TYPE MECHANICAL INDICATOR (Option : Flat side indicator)	EXTERNAL COATING	POWDER COATING
MANUAL OPERATION	N/A	INSIDE HEATER	1PH 220V/110 2W (Only AC)
TRAVEL ANGLE	90°		

► Drawing

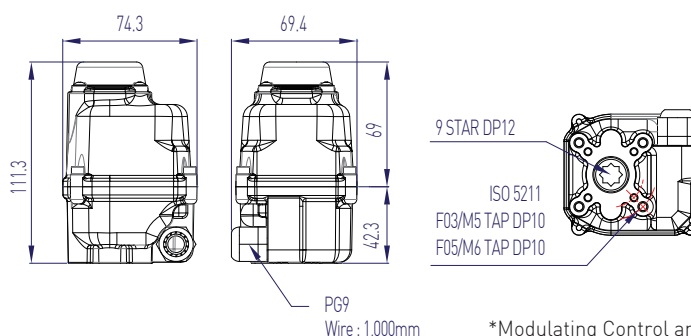

► SIDE INDICATOR OPTION



*Modulating Control and Aux.limit switch are released.

Contents

Model code

Performance Specification ISO5211&stem

Dimension

Wiring

Option table Modulating Control

DC control board 2 wire/3 wire

Local control

Explosion proof

► Performance

MODEL	MAX TORQUE (Nm)	OP. TIME 50/60Hz(sec)	RATED CURRENT(A)			MOTOR INSULATION /OUTPUT(AC-DC)	MANUAL TURNS
			AC(1PH) 50/60Hz		DC		
			110V	220V			
KE002	20	17.5/14.5	0.29/0.25	0.12/0.1	1.5	E-B/10W-10W	3
#KE002-10N	10	7/6	0.29/0.25	0.12/0.1	1.5	E-B/10W-10W	3
KE004	40	12/10	0.67/0.6	0.23/0.2	2	E-B/10W-10W	3
#KE004-15N	15	8.5/7	0.67/0.6	0.23/0.2	2	E-B/10W-10W	3
KE005	50	13	(100-250V AC) 0.1-0.25		2	B-B/10W-10W	18
#KE005-20N	20	6	(100-250V AC) 0.1-0.25		2	B-B/10W-10W	18
KE006	60	18/15	0.67/0.6	0.23/0.2	2	E-B/10W-10W	3
#KE006-25N	25	8/6.5	0.67/0.6	0.23/0.2	2	E-B/10W-10W	3
KE008	80	17/14	0.53/0.50	0.33/0.29	2.5	F-B/10W-10W	20
#KE008-40N	40	8/6	0.53/0.50	0.33/0.29	2.5	F-B/10W-10W	20

MODEL	MAX TORQUE (Nm)			OP. TIME 50/60Hz (sec)	RATED CURRENT (A)					MOTOR INSULATION /OUTPUT(AC-DC)	MANUAL TURNS
	0°	45°	90°		AC(1PHASE)		AC(3PHASE)		DC		
					110V	220V	380V	440V			
KE010	100	65	100	22/18	0.82/0.75	0.42/0.40	N/A	N/A	2.5	F-B/10W-15W	15
#KE010-80N	80	50	80	18/14	0.82/0.75	0.42/0.40	N/A	N/A	2.5	F-B/10W-15W	11
#KE010-60N	60	40	60	11/14	0.82/0.75	0.42/0.40	N/A	N/A	2.5	F-B/10W-15W	9
KE016	160	107	160	28/23	0.94/0.85	0.50/0.46	0.47/0.37	0.62/0.49	4	F-B/15W-15W	19
#KE160-130N	130	85	130	22/18	0.94/0.85	0.50/0.46	0.47/0.37	0.62/0.49	4	F-B/15W-15W	16
#KE160-100N	100	65	100	18/14	0.94/0.85	0.50/0.46	0.47/0.37	0.62/0.49	4	F-B/15W-15W	13
KE028	280	190	280	40/33	0.94/0.85	0.50/0.46	0.47/0.37	0.62/0.49	4	F-B/15W-15W	23
#KE028-240N	240	160	240	30/25	0.94/0.85	0.50/0.46	0.47/0.37	0.62/0.49	4	F-B/15W-15W	19
#KE028-190N	190	125	190	24/20	0.94/0.85	0.50/0.46	0.47/0.37	0.62/0.49	4	F-B/15W-15W	15
KE040	400	270	400	40/33	1.09/1.23	0.54/0.58	0.16/0.15	0.18/0.16	5.5	F-B/25W-40W	23
#KE040-350N	350	240	350	30/25	1.09/1.23	0.54/0.58	0.16/0.15	0.18/0.16	5.5	F-B/25W-40W	19
#KE040-300N	300	220	300	24/20	1.09/1.23	0.54/0.58	0.16/0.15	0.18/0.16	5.5	F-B/25W-40W	15
KE050	500	350	500	40/33	1.55/1.75	0.72/0.90	0.30/0.28	0.40/0.30	N/A	F/40W	23
#KE050-450N	450	310	450	30/25	1.55/1.75	0.72/0.90	0.30/0.28	0.40/0.30	N/A	F/40W	19
#KE050-400N	400	280	400	24/20	1.55/1.75	0.72/0.90	0.30/0.28	0.40/0.30	N/A	F/40W	15
KE080	800	540	800	51/42	1.97/2.83	1.09/1.46	0.5/0.54	0.57/0.55	N/A	F/60W	77
KE120	1200	800	1200	51/42	1.97/2.83	1.09/1.46	0.5/0.54	0.57/0.55	N/A	F/90W	77

*Maximum current can be +30% from rated current. #Option

► ISO5211 & stem

	Standard	Option	Wt (Kg)
KE002	F03/05, 11*11		0.9
KE004	F03/05/07, 11*11	14*14	1.5
KE005	F03/05/07, 14*14	11*11	1.3
KE006	F03/05/07, 14*14		1.9
KE008	F03/05/07, 14*14	F05/07, 17*17	2.6
KE010	F05/07, 14*14	17*17	3.0
KE016	F05/07/10, 17*17		6.2
KE028	F07/10, 22*22	F07/10/12, 27*27	8.9
KE040	F07/10, 22*22	F07/10/12, 27*27	9.4
KE050	F07/10, 22*22	F07/10/12, 27*27	9.4
KE080	F10/12, 36*36	F10/14, 36*36	26.0
KE120	F10/12, 36*36	F10/14, 36*36	26.0

► Standard specification

AMBIENT TEMPERATURE	-20℃~+60℃	
MOTOR CONDITION	Duty 40%	
INDICATOR	Dome type mechanical indicator	
AUX. LIMIT SWITCHES	KE002	N/A (in option)
	KE004-KE120	2 each for Open and Close 250VAC/5A
MANUAL OPERATION	KE002, KE004, KE006	By Spanner 5mm
	KE005, KE008	By Wrench 5mm
	KE010, KE016	By Wrench 6mm (Hand wheel in option)
	KE028, KE040, KE050	By Wrench 8mm (Hand wheel in option)
	KE080, KE120	By clutchless Hand Wheel
TRAVEL ANGLE	90°+5°	
INTERNAL HEATER (Only AC)	(KE002,KE004,KE006,KE008) N/A (KE005,KE008-KE120) 1PH 220/110V AC	
CABLE ENTRY	(KE002) Cable wire (1000mm,6000mm in option) (KE004/KE006) Terminal box (1-PF1/2) (KE005/KE008-KE120) Terminal box (2-PF1/2)	

Contents

Model code

Performance Specification
ISO5211&stem

Dimension

Wiring

Option table
Modulating Control

DC control board
2 wire/3 wire

Local control

Explosion proof

Dimension

Contents

Model code

Performance Specification ISO5211&stem

Dimension

Wiring

Option table Modulating Control

DC control board 2 wire/3 wire

Local control

Explosion proof

T

T

AL KE002

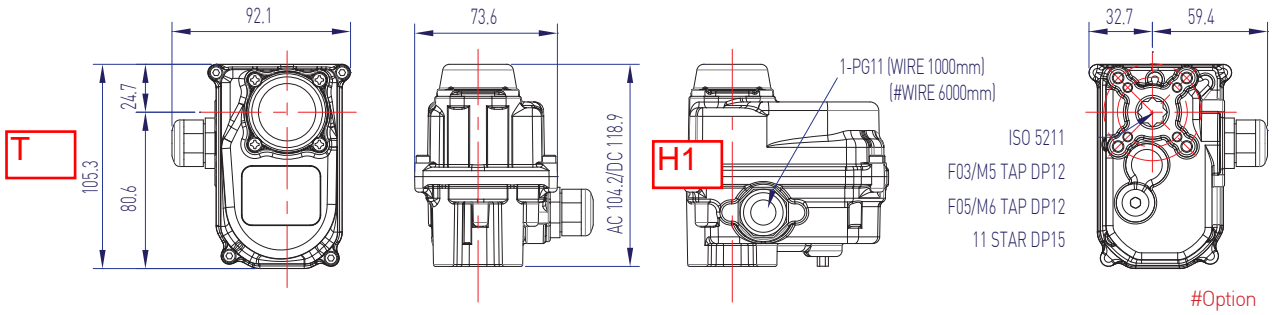

AL KE004 / KE006 / KE008

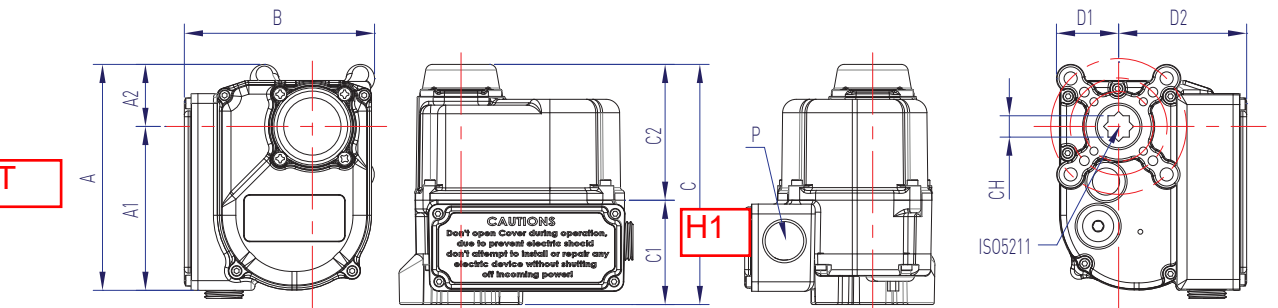

MODEL	T	A1	A2	AL	H1	C1	C2	D1	D2	ISO5211	P.C.D	N-M	CH	DTH	P
KE004	116.5	32	84.5	98.1	123.8	53.8	70	32	66	F03/F05/F07	36/50/70	4-M5/M6/M8	11*11	15	1-PF1/2
													#14*14	16	
KE006	122	34.2	97.9	111.3	134.5	59	75.5	39	72.3	F03/F05/F07	36/50/70	4-M5/M6/M8	14*14	16	1-PF1/2
KE008	125.3	33.7	91.6	122.3	155.5	81.5	74	42.3	80	¹⁾ F03/F05/F07	36/50/70	4-M5/M6/M8	14*14	16	2-PF1/2
										¹⁾ #F05/07	50/70	4-M6/M8	17*17	19	

¹⁾You can choose only F03/F05/F07 with 14*14 or F05/F07 with 17*17.

#Option

KE005

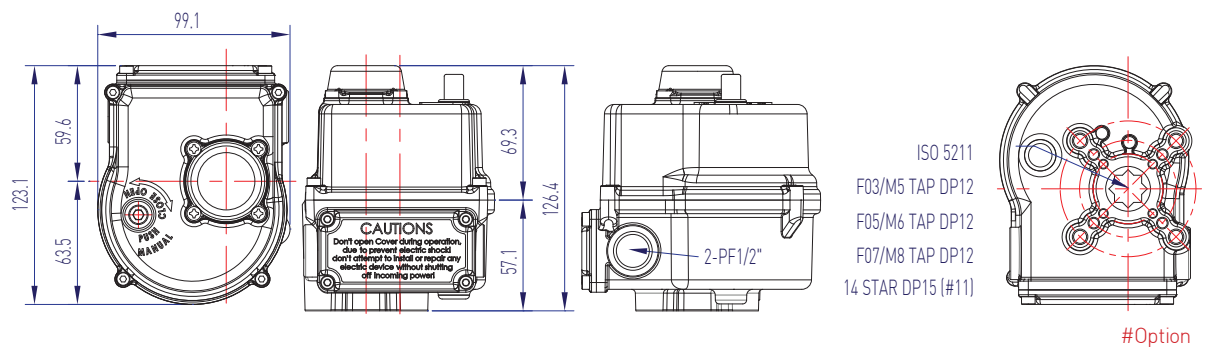

#Option

T **AL** KE010

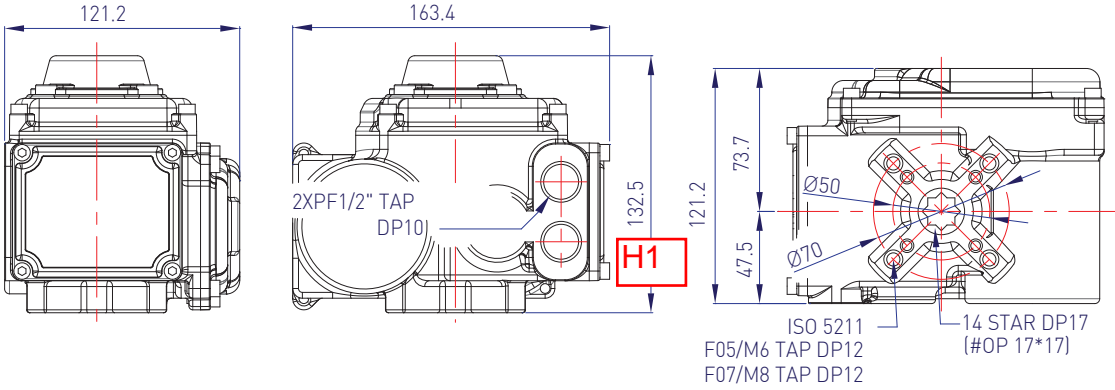

T **AL** KE016 / KE028 / KE040 / KE050

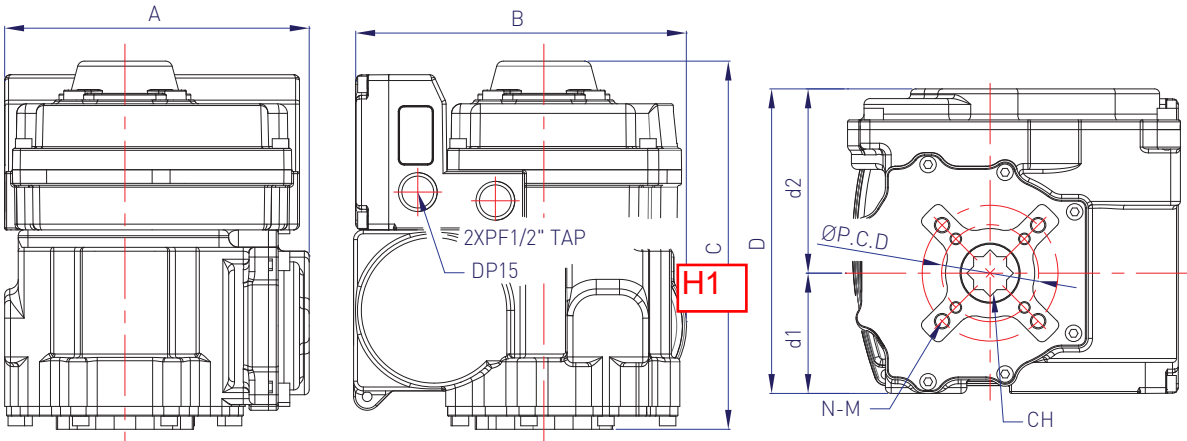

MODEL	T	AL	H1	D	d1	d2	ISO	P.C.D	N-M	CH	DTH
KE016	157.0	170.5	189.8	157	62	95	F05/F07/F10	50/70/102	4-M6/M8/M10	17x17	19
KE028							¹ F07/F10	70/102	4-M8/M10	22x22	24
KE040	181.9	208.9	209.0	181.9	73.7	108.2	¹ #F07/F10/F12	#70/102/125	4-M8/M10/M12	#27x27	29
KE050											

You can choose only F07/F10 with 22*22 or F07/F10/F12 with 27*27. #Option

T **AL x** KE080 / KE120

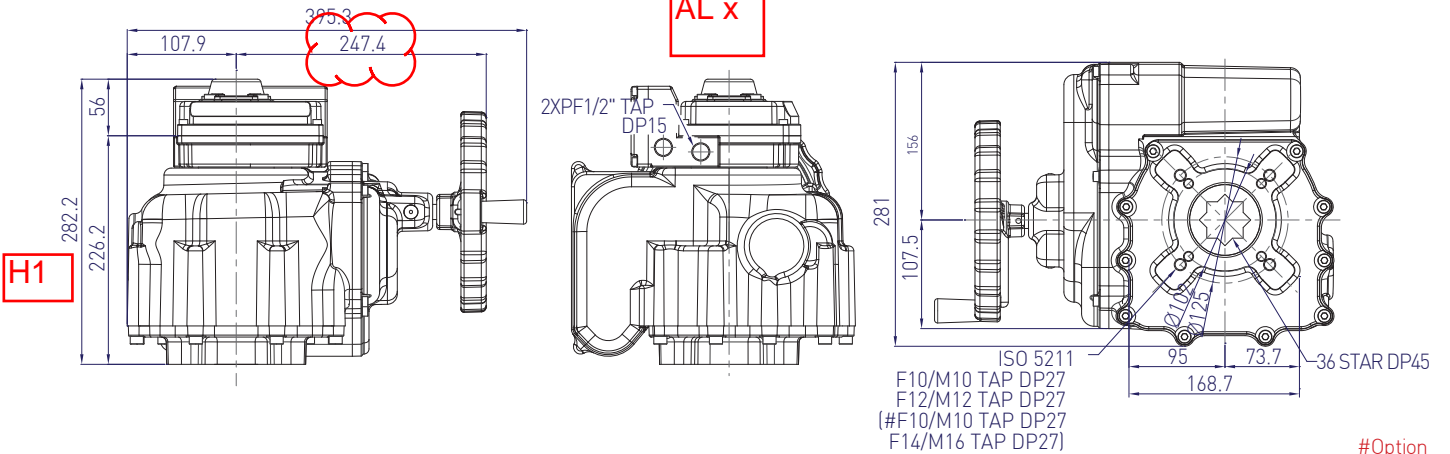

Contents

Model code

Performance Specification ISO5211&stem

Dimension

Wiring

Option table Modulating Control

DC control board 2 wire/3 wire

Local control

Explosion proof

Wiring

- 1) If two or more electric actuators are operated, there must be individual relays for each actuator.
- 2) Each actuator should have two relays (a relay for OPEN and a relay for CLOSE) respectively.

Contents

Model code

Performance Specification ISO5211&stem

Dimension

Wiring

Option table Modulating Control

DC control board 2 wire/3 wire

Local control

Explosion proof

KE002

AC 1PH

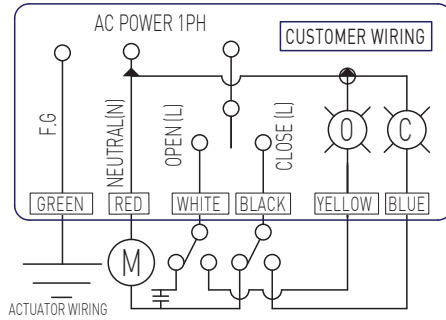

DC 24V

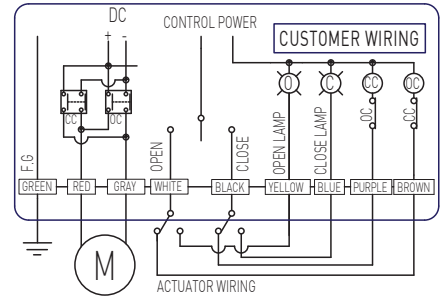

SWITCH WIRING (POSITION : FULL CLOSE)

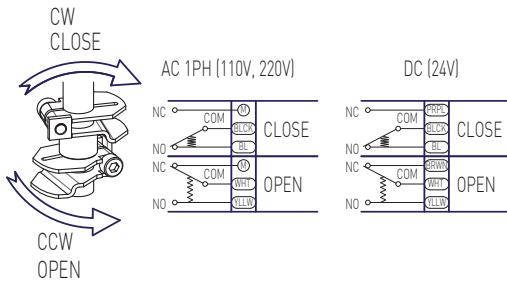

LIMIT SWITCH OPERATION

SWITCH	CLOSE	← INTERMEDIATE	→ OPEN
CLS COM-NC		█	
CLS COM-NO	█		
OLS COM-NC	█		
OLS COM-NO			█

KE004 / KE005 / KE006

AC 1PH

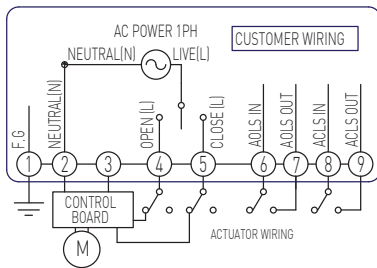

DC 24V (KE004/KE006)

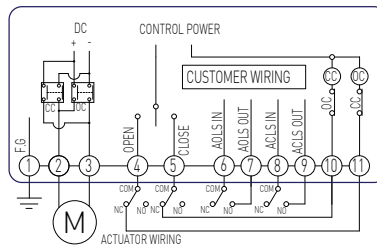

DC 24V (KE005)

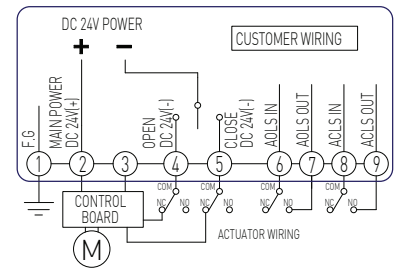

SWITCH WIRING (POSITION : FULL CLOSE)

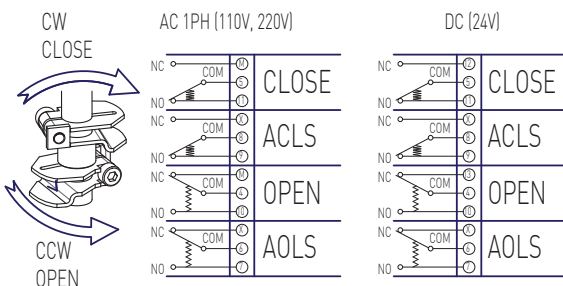

LIMIT SWITCH OPERATION

SWITCH	CLOSE	← INTERMEDIATE	→ OPEN
CLS COM-NC		█	
CLS COM-NO	█		
ACLS COM-NC		█	
ACLS COM-NO	█		
OLS COM-NC	█		
OLS COM-NO			█
AOLS COM-NC	█		
AOLS COM-NO			█

KE008 ~ KE120

▶ AC 1PH

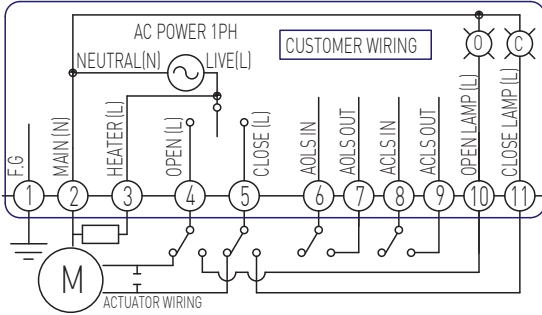

▶ DC 24V (KE008-KE040)

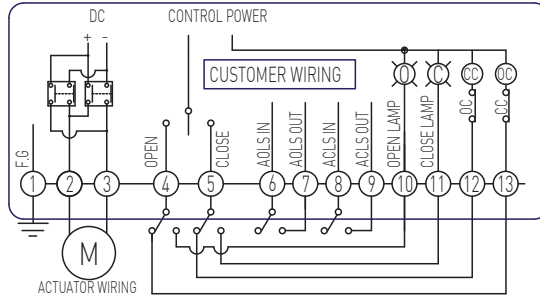

▶ AC 3PH (KE016-KE120)

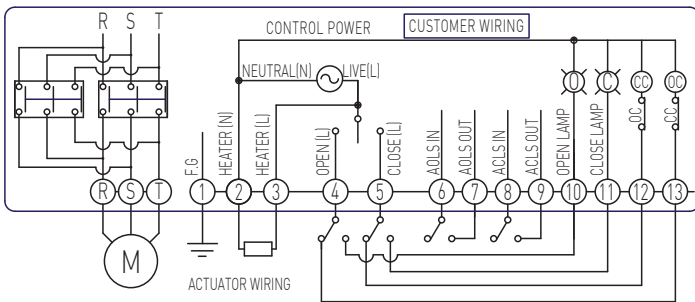

▶ LIMIT SWITCH OPERATION

SWITCH	CLOSE	← INTERMEDIATE	→ OPEN
CLS COM-NC		█	█
CLS COM-NO	█		
ACLS COM-NC		█	█
ACLS COM-NO	█		
OLS COM-NC	█		
OLS COM-NO			█
AOLS COM-NC	█		
AOLS COM-NO			█

▶ SWITCH WIRING (POSITION : FULL CLOSE)

▶ KE008

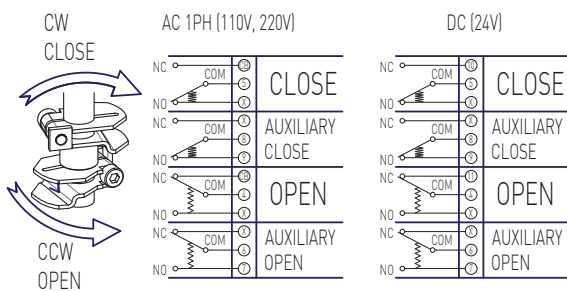

▶ KE010 ~ KE120

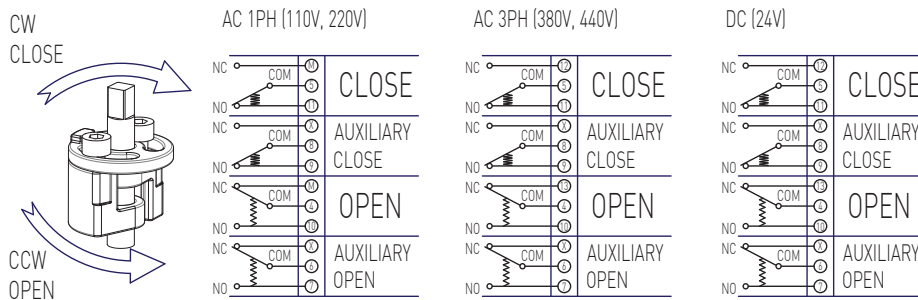

Contents

Model code

Performance Specification ISO5211&stem

Dimension

Wiring

Option table Modulating Control

DC control board 2 wire/3 wire

Local control

Explosion proof

Contents

Model code

Performance Specification ISO5211&stem

Dimension

Wiring

Option table
Modulating Control

DC control board
2 wire/3 wire

Local control

Explosion proof

Option table

Option	Description	Model											
		KE002	KE004	KE005	KE006	KE008	KE010	KE016	KE028	KE040	KE050	KE080	KE120
WT	Watertight (IP68 5m 120hr)	○	○	○	○	○	○	○	○	○	○	○	○
TS	Electric Torque switches								○	○	○	○	○
MC	Modulating Control (4-20mA)	1ph	○	○	○	○	○	○	○	○	○	○	○
SM	Modulating cotrol (4-20mA,0-1V,2-10V,0-5V,1-5V)	1ph	○	○	○	○			○	○	○	○	○
		24v dc	○	○	○	○	○	○	○	○			
LC	Local Control (Electric torque switch included)	1ph							○	○	○	○	○
		3ph							○	○	○	○	○
LM	Local and Modulating control (Electric torque switch included)	1ph							○	○	○	○	○
		3ph							○	○	○	○	○
C2	24V DC Control board (2 Wire)	○	○		○								
C3	24V DC Control board (3 Wire)	○	○	Standard Included	○								
TP	Thermal Protection												(Only AC) Standard Included
HT	Heater			(Only AC) Standard Included									(Only AC) Standard Included
TH	Thermal Protection and Heater	○	○		○								

Wiring

MC&SM (Modulating Control)

*Wiring for MC and SM are the same.

AC 1PH (KE002-KE006)

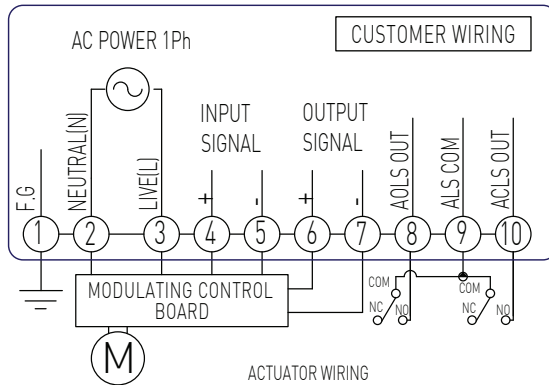

AC 1PH (KE008-KE120)

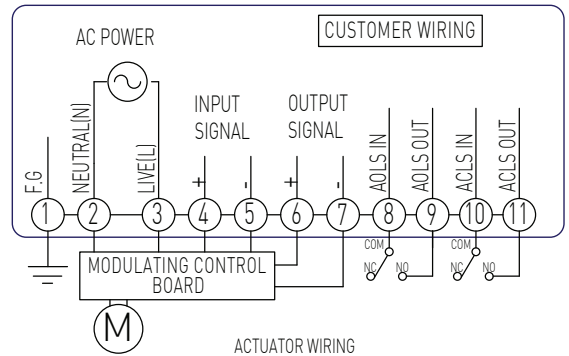

KE008

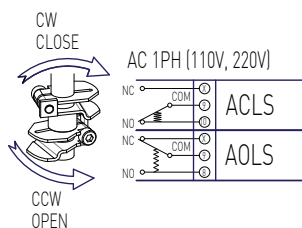

KE010-KE120

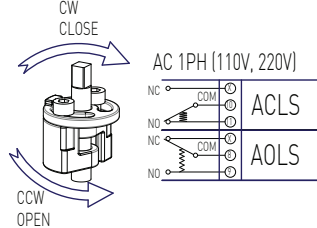

LIMIT SWITCH OPERATION

SWITCH	CLOSE	← INTERMEDIATE	→ OPEN
CLS COM-NC		█	
CLS COM-NO			█
ACLS COM-NC		█	
ACLS COM-NO			█
OLS COM-NC	█		
OLS COM-NO			█
AOLS COM-NC	█		
AOLS COM-NO			█

* Dimensions for models with MC option are different from standard. (KE001, KE002, KE004, KE006, KE010-KE120)

C2 (24V DC Control board 2 Wire)

▶ KE002

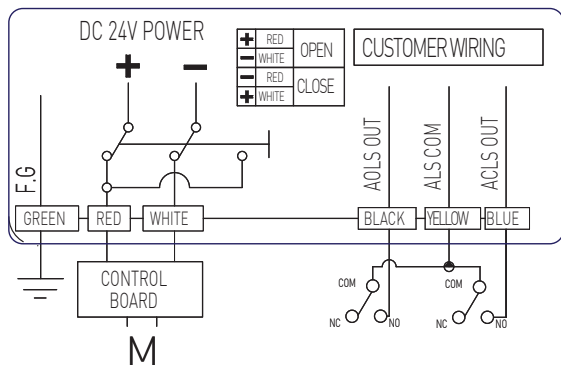

▶ SWITCH WIRING (POSITION : FULL CLOSE)

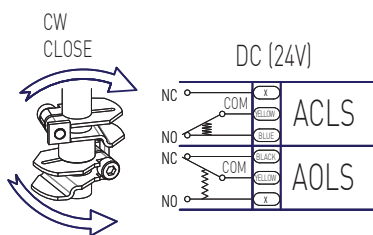

▶ KE004/KE006/KE008

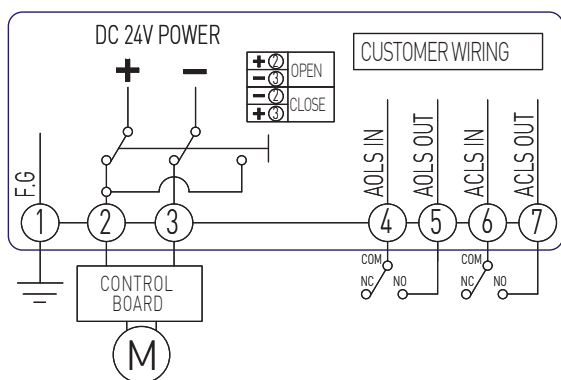

▶ SWITCH WIRING (POSITION : FULL CLOSE)

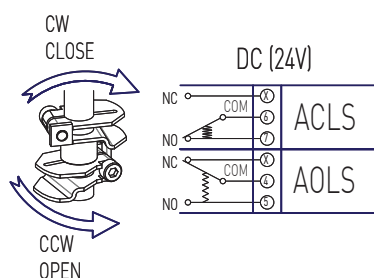

C3 (24V DC Control board 3 Wire)

▶ KE002

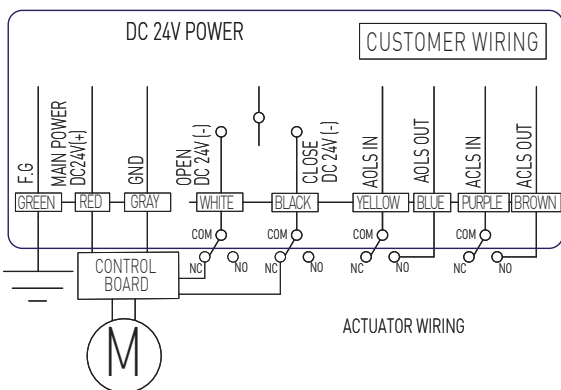

▶ SWITCH WIRING (POSITION : FULL CLOSE)

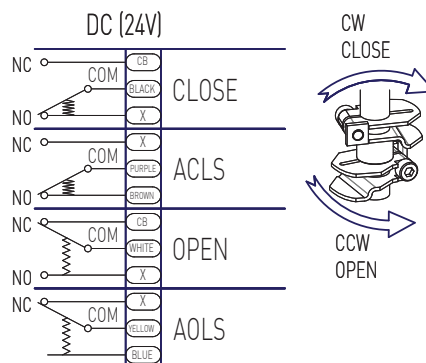

▶ KE004/KE006

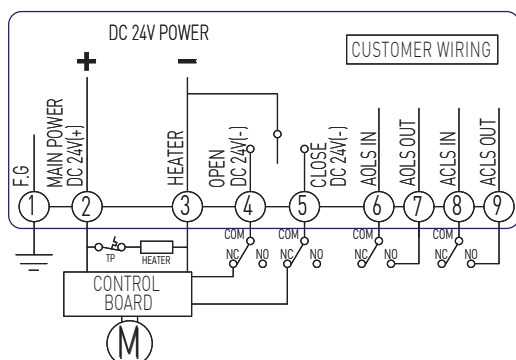

▶ SWITCH WIRING (POSITION : FULL CLOSE)

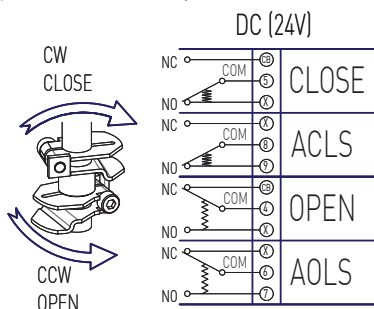

Contents

Model code

Performance Specification ISO5211&stem

Dimension

Wiring

Option table Modulating Control

DC control board 2 wire/3 wire

Local control

Explosion proof

Contents

- Model code
- Performance Specification ISO5211&stem
- Dimension

Wiring

Option table Modulating Control

DC control board 2 wire/3 wire

Local control

Explosion proof

LC (Local Control)

MODEL RANGE	<ul style="list-style-type: none"> · 1ph Local control · 3ph Local control · 1ph Local control with Modulating control (Torque switch is included) · 3ph Local control with Modulating control (Torque switch is included) 	
AMBIENT TEMPERATURE INDICATOR	-20°C~+60°C Dome type mechanical indicator	
LIMIT SWITCHES	2 Each for Open and Close 250VAC/5A	
MANUAL OPERATION	KE016	By Wrench 6mm
	KE028, KE040, KE050	By Wrench 8mm
	KE080, KE120	BY Hand wheel
TRAVEL ANGLE	90°±5°	
CABLE ENTRY	3-PF1/2	



▶ Performance

MODEL	MAX TORQUE (Nm)			OP. TIME 50/60Hz (sec)	RATED CURRENT (A)				MOTOR INSULATION /OUTPUT(AC-DC)	MANUAL TURNS	
	0°	45°	90°		AC(1PHASE)		AC(3PHASE)				DC
KE016	160	107	160	28/23	0.94/0.85	0.50/0.46	0.47/0.37	0.62/0.49	4	F-B/15W-15W	19
#KE160-130N	130	85	130	22/18	0.94/0.85	0.50/0.46	0.47/0.37	0.62/0.49	4	F-B/15W-15W	16
#KE160-100N	100	65	100	18/14	0.94/0.85	0.50/0.46	0.47/0.37	0.62/0.49	4	F-B/15W-15W	13
KE028	280	190	280	40/33	0.94/0.85	0.50/0.46	0.47/0.37	0.62/0.49	4	F-B/15W-15W	23
#KE028-240N	240	160	240	30/25	0.94/0.85	0.50/0.46	0.47/0.37	0.62/0.49	4	F-B/15W-15W	19
#KE028-190N	190	125	190	24/20	0.94/0.85	0.50/0.46	0.47/0.37	0.62/0.49	4	F-B/15W-15W	15
KE040	400	270	400	40/33	1.09/1.23	0.54/0.58	0.16/0.15	0.18/0.16	5.5	F-B/25W-40W	23
#KE040-350N	350	240	350	30/25	1.09/1.23	0.54/0.58	0.16/0.15	0.18/0.16	5.5	F-B/25W-40W	19
#KE040-300N	300	220	300	24/20	1.09/1.23	0.54/0.58	0.16/0.15	0.18/0.16	5.5	F-B/25W-40W	15
KE050	500	350	500	40/33	1.55/1.75	0.72/0.90	0.30/0.28	0.40/0.30	N/A	F/40W	23
#KE050-450N	450	310	450	30/25	1.55/1.75	0.72/0.90	0.30/0.28	0.40/0.30	N/A	F/40W	19
#KE050-400N	400	280	400	24/20	1.55/1.75	0.72/0.90	0.30/0.28	0.40/0.30	N/A	F/40W	15
KE080	800	540	800	51/42	1.97/2.83	1.09/1.46	0.5/0.54	0.57/0.55	N/A	F/60W	77
KE120	1200	800	1200	51/42	1.97/2.83	1.09/1.46	0.5/0.54	0.57/0.55	N/A	F/90W	77

*Maximum current can be +30% from rated current.

#Option

▶ Wiring

● 1PH LC (KE016, KE028, KE040, KE050, KE080, KE120)

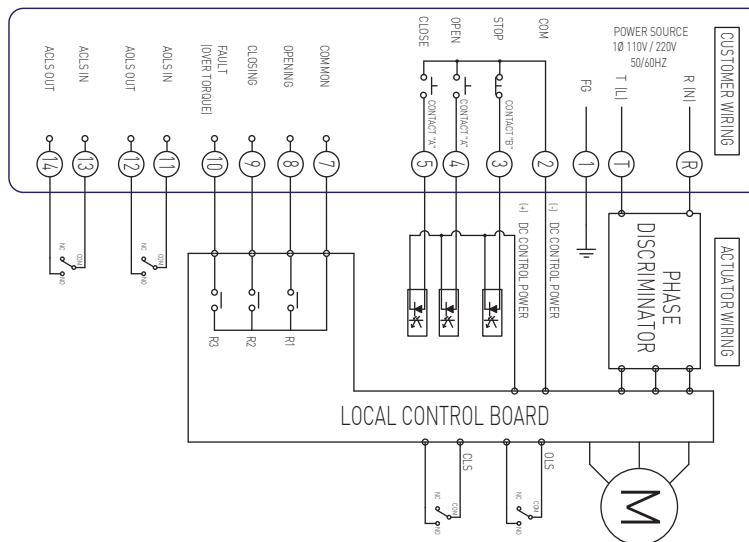

STOP : REMOTE MODE ACTUATOR STOP
 OPEN : REMOTE MODE OPEN RUNNING
 CLOSE : REMOTE MODE CLOSE RUNNING
 R1 : OPENING MONITOR RELAY
 R2 : CLOSING MONITOR RELAY
 R3 : FAULT RELAY
 OLS : OPEN LIMIT SWITCH
 CLS : CLOSE LIMIT SWITCH

► Standard specification

	KPxyyy (y=002,006,008,010)	KPxzzz (z=016,028,040,050)
ENCLOSURE	Ex d IIB T4 IP67	Ex db IIB T4 Gb IP67
AMBIENT TEMPERATURE	-20°C~70°C	-20°C~60°C
INDICATOR	KPF-Flat type, KPD-Dome type	
LIMIT SWITCHES	2 Each for Open and Close 250VAC/5A	
MANUAL OPERATION	By Spanner 5mm	By Declutch handwheel
TRAVEL ANGLE	90°±5°	
CABLE ENTRY	2-PF1/2	3-PF1/2



► Performance

MODEL	MAX TORQUE (Nm)			OPERATING TIME 50Hz/60Hz (sec)	RATED CURRENT (A)				MOTOR CLASS/OUTPUT (AC · DC)	MANUAL TURNS	
	0°	45°	90°		AC (1PH) 50/60Hz		AC (3PH) 50/60Hz				DC
					110V	220V	380V	440V			
KPx002	25			8/6.5	0.67/0.6	0.23/0.2			2	E · B/10W · 10W	6
KPx006	60			18/15	0.67/0.6	0.23/0.2			2	E · B/10W · 10W	6
KPx008	80			34/28	0.67/0.6	0.23/0.2			2	E · B/10W · 10W	6
KPx010	100			42/35	0.67/0.6	0.23/0.2			2	E · B/10W · 10W	6
KPx016	160	107	160	28/23	0.94/0.85	0.50/0.46	0.47/0.37	0.62/0.49	4	F · B/25W · 40W	19
KPx028	280	190	280	40/33	0.94/0.85	0.50/0.46	0.47/0.37	0.62/0.49	4	F · B/25W · 40W	23
KPx040	400	270	400	40/33	1.09/1.23	0.54/0.58	0.16/0.15	0.18/0.16	5.5	F · B/25W · 40W	23
KPx050	500	350	500	40/33	1.55/1.75	0.72/0.90	0.30/0.28	0.40/0.30		F40W	23

► Drawing

► AC 1PH
KPXyyy (y=002, 006, 008, 010)

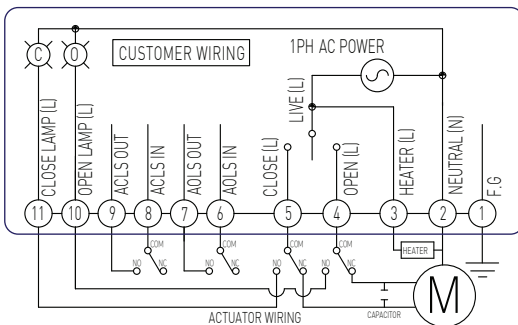

► AC 1PH
KPXzzz (y=016, 028, 040, 050)

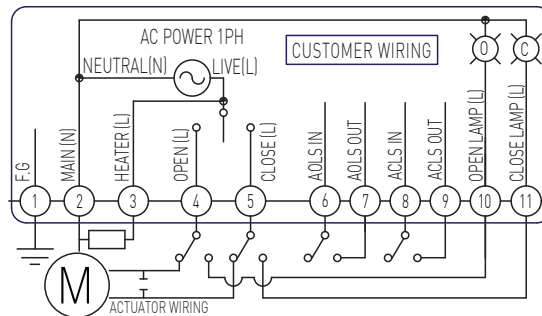

Contents

Model code

Performance Specification
ISO5211&stem

Dimension

Wiring

Option table
Modulating Control

DC control board
2 wire/3 wire

Local control

Explosion proof

► ISO5211 & stem

	Standard	Option	Wt (Kg)
KE002	F03/05, 11*11		0.9
KE004	F03/05/07, 11*11	14*14	1.5
KE005	F03/05/07, 14*14	11*11	1.3
KE006	F03/05/07, 14*14		1.9
KE008	F03/05/07, 14*14	F05/07, 17*17	2.6
KE010	F05/07, 14*14	17*17	3.0
KE016	F05/07/10, 17*17		6.2
KE028	F07/10, 22*22	F07/10/12, 27*27	8.9
KE040	F07/10, 22*22	F07/10/12, 27*27	9.4
KE050	F07/10, 22*22	F07/10/12, 27*27	9.4
KE080	F10/12, 36*36	F10/14, 36*36	26.0
KE120	F10/12, 36*36	F10/14, 36*36	26.0
KP010	F03/05/07, 14*14		6.3

► Option table

Option	Description	Model											
		KE002	KE004	KE005	KE006	KE008	KE010	KE016	KE028	KE040	KE050	KE080	KE120
WT	Watertight (IP68 5m 120hr)	○	○	○	○	○	○	○	○	○	○	○	○
TS	Electric Torque switches							○	○	○	○	○	○
MC	Modulating Control (4-20mA)	1ph	○	○	○	○	○	○	○	○	○	○	○
SM	Modulating control (4-20mA,0-1V,2-10V,0-5V,1-5V)	1ph	○	○	○	○	○	○	○	○	○	○	○
		24v dc	○	○	○	○	○	○	○	○			
LC	Local Control (Electric torque switch included)	1ph						○	○	○	○	○	○
		3ph						○	○	○	○	○	○
LM	Local and Modulating control (Electric torque switch included)	1ph						○	○	○	○	○	○
		3ph						○	○	○	○	○	○
C2	24V DC Control board (2 Wire)	○	○		○	○	○						
C3	24V DC Control board (3 Wire)	○	○	Standard Included	○								
TP	Thermal Protection		○		○								[Only AC] Standard Included
HT	Heater			[Only AC] Standard Included									[Only AC] Standard Included
TH	Thermal Protection and Heater	○	○		○								

KOSA PLUS

KOSAPLUS Co.,Ltd.

294, Gongdan2daero, Siheung, Gyeonggi, 15115, S.Korea (<http://www.kosaplus.com>)

· E-mail : oversea@kosaplus.com · Tel : +82-31-433-3159 / Fax : +82-31-433-3151

Catalog version : 5.2 (May. 2022)

- Data contained in the Catalog may be subject to change without advance notice for improvement of performance&safety of Product.

- Contact us for the most recent product and technical information. Visit our website for more details: <http://www.kosaplus.com>