

rotork®

Keeping the World Flowing
for Future Generations

Valve Positioners and Accessories

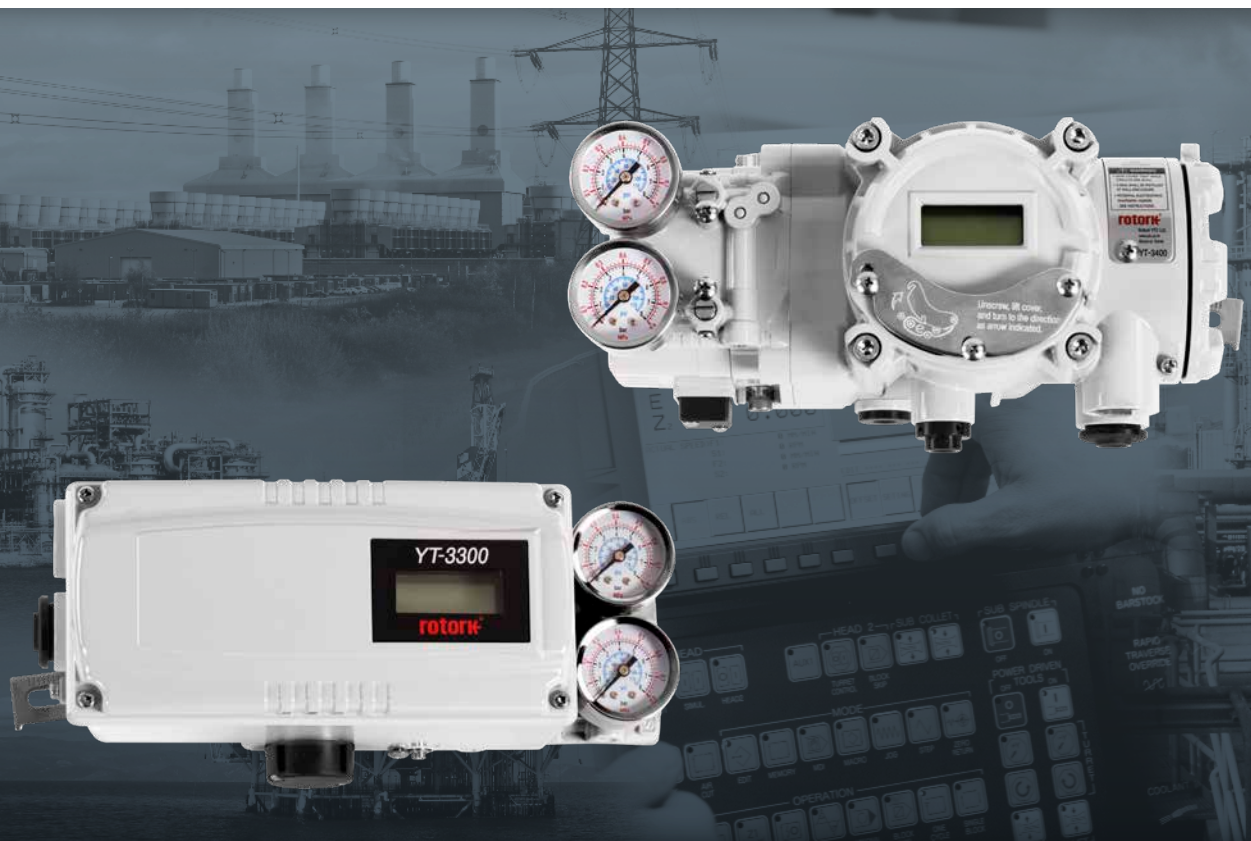

Reliability in critical flow control applications



› Reliable operation when it matters

Assured reliability for critical applications and environments. Whether used infrequently or continuously, Rotork products will operate reliably and efficiently.

› Quality-driven global manufacturing

We offer products that have been designed with over 60 years of industry and application knowledge.

Our research and development ensures cutting edge products are available for multiple applications across multiple industries.

› Customer focused service and worldwide support

Rotork solve customer challenges and develop new solutions that are tailored to the needs of our clients.

We offer dedicated, expert service and support from initial inquiry, to product installation, to long-term after-sales care.

› Low cost of ownership

Long-term reliability prolongs service life.

Rotork helps to reduce long-term cost of ownership and provides greater efficiency to process and plant.

Valve Positioners and Accessories

Section	Page	Section	Page
Valve Positioner Features Summary	4	Snap Acting Relays	32
Smart Positioner Selection	6	Solenoid Valve	33
Multiple Bus Connectivity	7	Position Transmitters	34
Enhanced Diagnostic Capabilities	8	Limit Switch Boxes	36
Smart Positioners	10	Examples for Installation (Linear Type)	38
IP Converters	28	Brackets and Levers	40
Air Filter Regulators	29	Appendix A: Equipment Certification Requirements for Hazardous Locations	42
Volume Boosters	30	Appendix B: Certifications	44
Lock-up Valves	31	Site Services	46



Comprehensive product range serving multiple industries

Rotork products offer improved efficiency, assured safety and environmental protection across sectors such as the Power, Oil & Gas, Water & Wastewater, HVAC, Marine, Mining, Pulp & Paper, Food & Beverage, Pharmaceutical and Chemical sectors.

Market leaders and technical innovators

We have been the recognised market leader in flow control for over 60 years.

Our customers rely upon Rotork for innovative solutions to safely manage the flow of liquids, gases and powders.

Global presence, local service

We are a global company with local support.

Manufacturing sites, service centres and sales offices throughout the world provide unrivalled customer services, fast delivery and ongoing, accessible support.

Environmental, Social and Governance is at the heart of our business

Our ambition is to become recognised as a sustainability leader within our industry. We are positioning ourselves to better understand and predict customers' needs and play our fullest role in enabling smart solutions for global sustainability challenges.

Valve Positioner Features Summary



Type	Top Mounted	P/P	E/P		Smart		
Model	TMP-3000	YT-1200	YT-1000	YT-1050	YT-2500	YT-2550	
Page	10	11	12		24		
Certification	Flame proof	-	-	✓	-	-	
	Intrinsically safe	-	-	✓	-	✓	
	ATEX/IECEX	-	-	✓	-	✓	
	FM/CSA	-	-	✓	-	-	
	KCs	-	-	✓	-	✓	
	EAC	-	-	✓	-	✓	
	CCC (or NEPSI)	-	-	✓	-	✓	-
	TIIS	-	-	✓	-	-	-
	TS	-	-	✓	-	-	-
	EMC	✓	-	✓	-	✓	-
SIL Certified	-	-	-	-	-	-	
Hardware	Technology	Solenoid	Bellows	Torque Motor		Piezo	
	Local Buttons	✓	-	-		✓	
	LCD Display	✓	-	-		✓	
	Single / Double	✓	✓	✓		✓	
	Linear / Rotary	Linear Only	✓	✓		✓	
	Feedback	NCS	Spring Return	Spring Return		Potentiometer	
	Fail-safe	✓	✓	✓		✓	
	Fail-freeze	✓	-	-		✓	
	Natural Gas capability	-	-	-		-	
	IP Rating	IP67	IP66	IP66		IP66	
NEMA rating	-	-	NEMA 4X		-		
Enclosure Material	PPS	Aluminium	Aluminium	STS316	Aluminium	STS316	
Diagnostics	Mounting Error	-	-	-		✓	
	Supply Air Check	-	-	-		✓	
	Range Error	-	-	-		✓	
	Partial Stroke Test	-	-	-		-	
	Enhanced Diagnostics	-	-	-		-	
Feedback Option	Analogue 4 - 20 mA	-	✓ ¹	✓		✓	
	Mechanical switches	-	✓ ¹	✓ ¹		✓	
	Proximity sensors	-	✓ ¹	✓ ¹		✓	
	Digital output (or TR output)	-	-	-		-	
Comm.	HART®	-	-	-		Ver. 5	
	Profibus®	-	-	-		-	
	Foundation Fieldbus®	-	-	-		-	

Notes:

1. Available for rotary version only. In case of hazardous Ex installation area external mount through limit switch box is required.
2. EMC only for YT-3301, not for YT-3303.
3. Available with potentiometer feedback.



Smart								
YT-2600	YT-3100	YT-3300	YT-3350	YT-3301/2/3	YT-3700	YT-3750	YT-3400	YT-3450
26	14	16		18	20		22	
✓	-	-	-	-	-	-	-	✓
-	✓	✓	✓	✓	✓	✓	✓	-
✓	✓	✓	✓	✓	✓	✓	✓	✓
-	-	✓	✓	✓	✓	✓	✓	✓
✓	✓	✓	✓	✓	✓	✓	✓	✓
✓	-	✓	✓	✓	✓	✓	✓	✓
-	✓	✓	✓	✓	✓	✓	✓	✓
-	-	-	-	-	-	-	-	-
-	-	-	-	-	-	-	-	-
✓	-	✓	✓	✓ ²	✓	✓	✓	✓
-	-	✓	✓	✓	✓	✓	✓	✓
Piezo	Torque Motor	Torque Motor		Torque Motor	Torque Motor		Torque Motor	
✓	✓	✓	✓	✓	✓	✓	✓	✓
✓	✓	✓	✓	✓	✓	✓	✓	✓
✓	✓	✓	✓	✓	✓	✓	✓	✓
✓	✓	✓	✓	✓	✓	✓	✓	✓
Potentiometer	NCS	NCS		Potentiometer	NCS		NCS	
✓	✓	✓	✓	✓	✓	✓	✓	✓
✓	-	-	-	-	-	-	-	-
-	-	North America markets only		North America markets only	North America markets only		North America markets only	
IP66	IP66	IP66		IP66	IP66		IP66	
-	-	NEMA 4X		NEMA 4X	NEMA 4X		NEMA 4X	
Aluminium	Aluminium/Plastic	Aluminium	STS316	Aluminium	Aluminium	STS316	Aluminium	STS316
✓	✓	✓	✓	✓	✓	✓	✓	✓
✓	✓	✓	✓	✓	✓	✓	✓	✓
✓	✓	✓	✓	✓	✓	✓	✓	✓
-	-	✓	✓	✓	✓	✓	✓	✓
-	-	-	-	-	✓	✓	✓	✓
✓	✓	✓	✓	-	✓	✓	✓	✓
-	-	✓ ³	✓ ³	-	✓	✓	-	-
-	-	✓ ³	✓ ³	-	✓	✓	-	-
✓	-	-	-	-	✓	✓	✓	✓
Ver. 5	-	Ver. 7		Ver. 7	Ver. 7		Ver. 7	
-	-	✓	✓	-	-	-	-	-
-	-	✓	✓	-	-	-	-	-

Smart Positioner Selection

Application guide

Compact and lightweight design for modulating applications

- Fail safe
- Modulating functions
- PID control
- Optional 4-20mA feedback

YT-3100



Fail freeze applications

- Zero air consumption
- Modulating functions
- PID control
- Optional 4-20mA feedback

YT-2500



HART COMMUNICATION PROTOCOL

Extended features for all applications

- Fail safe
 - HART DD & DTM
 - Non-contact sensor
 - Basic PST capabilities
- YT-3300 only:
- Profibus, FF comm.
- YT-3400 only:
- Enhanced diagnostic
 - Digital I/O comm.
 - NE107 Alarms log

YT-3300



HART COMMUNICATION PROTOCOL

Enhanced diagnostic and PST for control and on-off valves

- Fail safe
- Enhanced diagnostic
- HART DD & DTM
- Digital I/O comm.
- NE107 Alarms log
- Non-contact sensor

YT-3700



HART COMMUNICATION PROTOCOL

Safe area and Hazardous area: Intrinsically safe protection



YT-2600



HART COMMUNICATION PROTOCOL

YT-3400



HART COMMUNICATION PROTOCOL

YT-3400

Enhanced diagnostic option



HART COMMUNICATION PROTOCOL

Hazardous area: Flameproof protection



Technical guide

Torque motor / flapper nozzle technology

- Extremely reliable
- Responsive and precise
- High resistance to humidity and contaminated air
- Low air consumption

YT-3100



Piezo valve technology

- Fail freeze (fail last)
- Zero air consumption

YT-2500



HART COMMUNICATION PROTOCOL

Torque motor / flapper nozzle technology

- Extremely reliable
- Responsive and precise
- High resistance to humidity and contaminated air
- Low air consumption

YT-3300



HART COMMUNICATION PROTOCOL

Torque motor / flapper nozzle technology

- Extremely reliable
- Responsive and precise
- High resistance to humidity and contaminated air
- Low air consumption

YT-3700



HART COMMUNICATION PROTOCOL

YT-2600



HART COMMUNICATION PROTOCOL

YT-3400



HART COMMUNICATION PROTOCOL

YT-3400

Enhanced diagnostic option



HART COMMUNICATION PROTOCOL

Low temperature application down to -30 °C

Arctic temperature application down to -55 °C

Multiple Bus Connectivity



HART Communication

The HART Communication Protocol (Highway Addressable Remote Transducer) is a hybrid, analogue and digital, industrial automation protocol.

HART provides two simultaneous communication channels: the 4-20 mA analogue signal and a digital signal. The 4-20 mA signal communicates the primary measured value. Additional device information is communicated using a superimposed digital signal on the analogue one.

Rotork can offer a complete positioner portfolio from fail-freeze (fail-last) to fail-safe devices, all including easy handling and commissioning via HART communication protocol.

- Device Description (DD) and Device Type Manager (DTM) files allow the Rotork device to be incorporated into asset management systems
- Up to 63 devices on each network



Profibus Process Automation (PA)

Profibus manages equipment via a process control system in process automation applications.

The PA variant is designed for use in hazardous areas (Ex zones 0 and 1). The Physical Layer, with over the bus power, limits current flow so that explosive conditions are not created, even if a malfunction occurs. The number of devices attached to a Profibus PA segment is limited by this feature. However, PA uses the same protocol as Profibus DP, and can be linked to a Profibus DP network using a coupler device.

The much faster Profibus DP acts as a backbone network for transmitting process signals to the controller. This means that Profibus DP and Profibus PA can work tightly together, especially in hybrid applications where process and factory automation networks operate side by side.

- Electronic Device Description (EDD) and Device Type Manager (DTM) files allow the Rotork device to be incorporated into asset management systems
- General Station Description (GSD) guarantees device interoperability with all Profibus PLCs



Foundation Fieldbus

Foundation Fieldbus is a bi-directional communications protocol used for communications among field devices and the control system.

It utilises twisted pair or fibre media to communicate between multiple nodes (devices) and the controller. The controller requires only one communication point to communicate with up to 32 nodes, this is a significant improvement over the standard 4-20 mA communication method which requires a separate connection point for each communication device on the controller system.

- Device Description (DD) files describe the device capabilities to the host system
- Fully compliant with IEC61158-2 standard

Enhanced Diagnostic Capabilities

Online diagnostics

These digital smart positioners employ continuous monitoring and graphic display of valve position, set point target vs time and internal circuit board temperature vs time.

Steady state deviation online analysis can detect:

- Friction in the valve or actuator
- Leakage in pneumatics
- Insufficient supply pressure



A deviation time out alarm occurs when the difference between the target position and the actual position exceeds the preset deviation alarm point (for more than the preset deviation time).

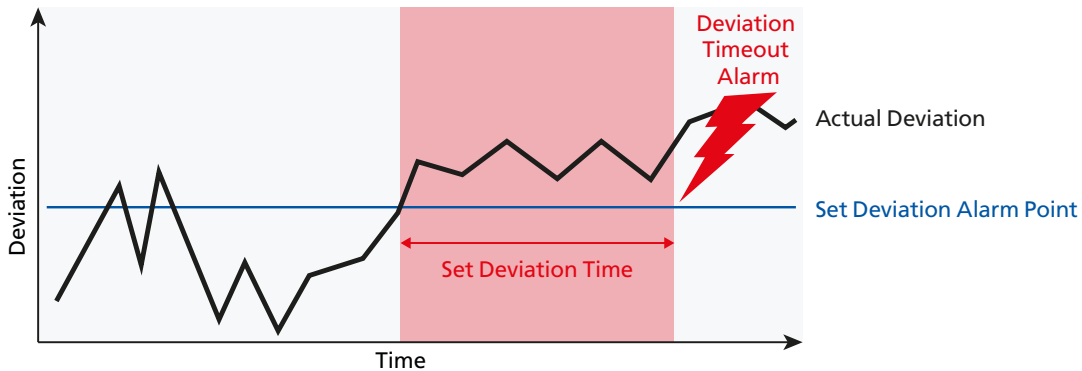

Alarms

Embedded memory can store up to 11 PST test results and up to 20 alarm logs. Through DTM, the history of files will be easy to detect and the valve system integrity easily verified.

Examples of user-configurable alarm/status based on NE107 status signal:

- Critical NVM failure
- Travel sensor failure
- RAM defect
- Drive Signal
- Temperature signal
- Deviation
- Travel accumulator
- Cycle counter
- Full close/open count
- PST failure
- Auto calibration failure

Note: Alarm severity can be set by operator

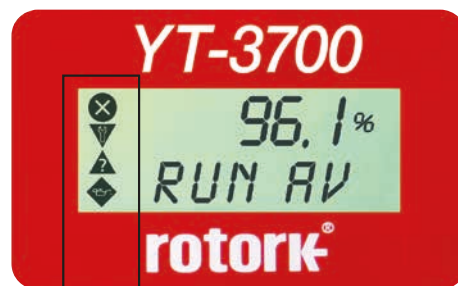

	Failure High severity
	Check function Signal temporarily invalid
	Out of specification Medium severity
	Maintenance required Low severity

Explanation of on-screen icons

Enhanced Diagnostic Capabilities

Offline diagnostics

Automated package tests, checking integrity and dynamic behaviour:

- Valve signature
- 25% step test
- Large step test
- Performance step test

These tests provide data to validate system performances. The system allows a reference to be set for further analysis highlighting performance shifts for predictive maintenance.

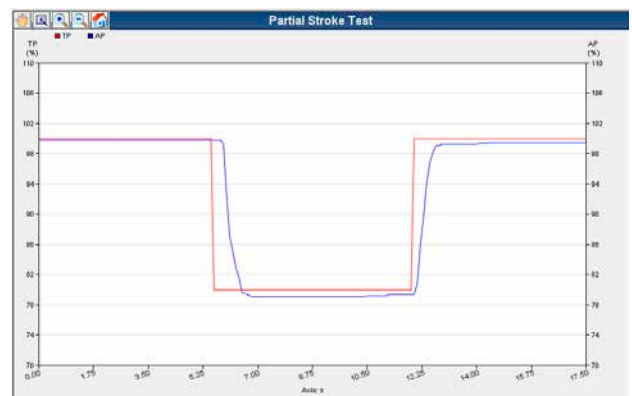
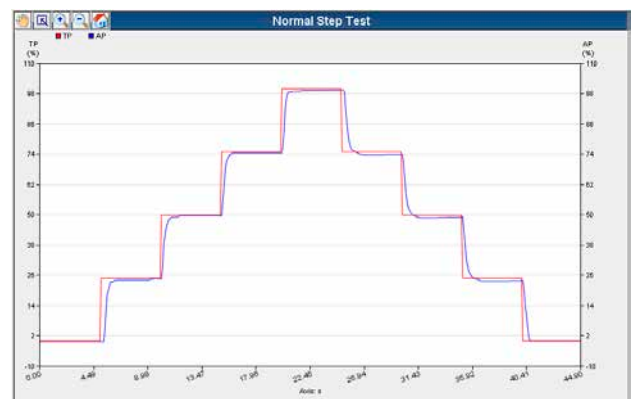
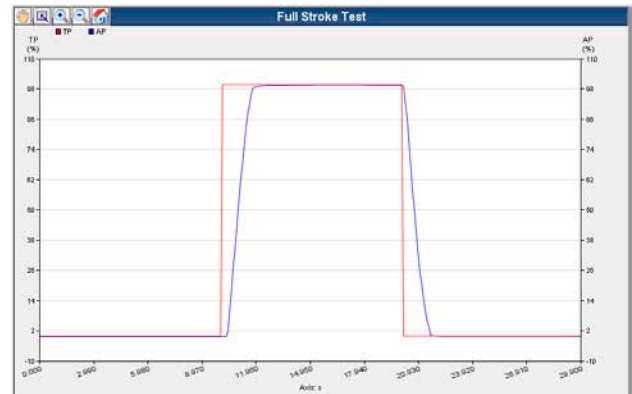

Partial Stroke Test capabilities

Automated PST functionality:

Configurable parameters

- PST interval [days]
- Position tolerance [%]
- PST start position [%]
- Target position [%]
- PST time out limit [sec]
- Target position hold time [sec]
- PST ramp up/down [%/sec] to reduce risks of overshooting system

Test activation via:

- Local positioner menu
- Remote DI control push button
- Remote HART® connection

Product line compatibility

Enhanced diagnostic capabilities are available for YT-3700, YT-3750, YT-3400 and YT-3450 series.

The above compatibility ensures enhanced diagnostics is available for use in safe and hazardous areas, using intrinsically safe or Ex d explosionproof protection methods. Aluminium or stainless steel construction materials provide flexibility to meet application demands.



Smart Positioner TMP-3000

Solenoid Technology

Design features

- **Vertical mounting.** Easy to mount installation.
- **Fail-freeze and fail-safe function.** Enables the valve maintain the last position (fail-freeze) or move to a pre-determined position (fail-safe) on the loss of electrical power supply or the pneumatic supply air.
- **LCD display.** Backlit alphanumeric digital display for process values and calibration.

- **Feedback signal.** 4-20 mA output option.
- **Auto calibration.** Simple menu structure with options to auto calibrate all parameters or zero and end points only.
- **Low air consumption level.** Almost zero air leakage.
- **Front panel pushbuttons for configuration.** Positive acting pushbuttons for field configuration.

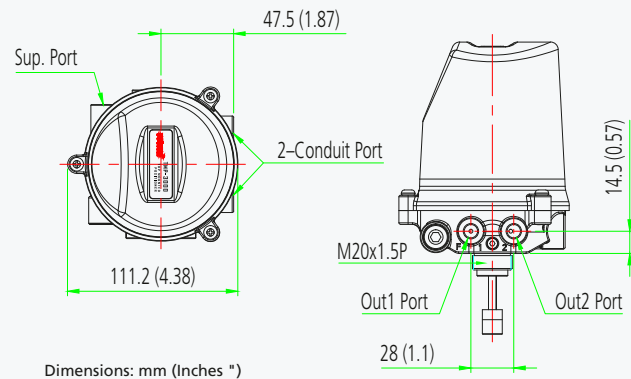

Dimensions: mm (Inches ")

Item Type	TMP-3000
Power Supply	24 VDC ± 10% More than 4W (167mA @24V) with Single acting More than 5.8W (242mA @24V) with Double acting
Input Signal	0-20 mA, 4-20 mA, 0-5 V, 0-10 V
Output	4-20 mA
Output Characteristics	Linear, EQ%, Quick Open, User Set (5 or 21 Points)
Operating Temp.	-10 to +60 °C (+14 to +140 °F)
Supply Pressure	0 to 0.7 MPa / 0 to 7 bar / 0 to 102 psi
Air Consumption	0 LPM (0 psi)
Flow Capacity	20 / 50 LPM (0.7 / 1.77 CFM)
Filtering Size	5 micron
Acting Type	Single 2 solenoid valves Double 4 solenoid valves
Stroke	5 to 40 mm (0.2 to 1.6")
Air Connection	G 1/8 (Ø 6 mm tube)
Conduit	2-M16 x 1.5P (with screw terminals)
Ingress Protection	IP67
Body Material	PPS
Cover Material	PC
Weight	750 g (1.7 lb)

Product Code

TMP-3000 - S - N - G - 1 - 0 - F

Model
TMP-3000 = Smart Positioner

Acting Type
S = Single
D = Double

Explosion Protection
N = Non-Explosionproof

Conduit & Air Connection
G = M16 x 1.5 - G1/8

Flow Capacity
1 = 20 LPM
2 = 50 LPM

Output Options
0 = None
1 = 4-20 mA feedback

Fail Option
F = Fail-freeze
S = Fail-safe

Pneumatic-Pneumatic Positioner YT-1200

Design features

- **Simple zero and span adjustment.** Internal hand dials and locking screws for 0.1 to 1 MPa range adjustments.
- **Reverse and direct acting settings.** Full and ½ split range setting by simple adjustment.
- **High vibration resistant.** No resonance between 5 to 200 Hz.
- **Auto / manual switch.** Internal adjustment with lock screw safety.



YT-1200 Aluminium Enclosure

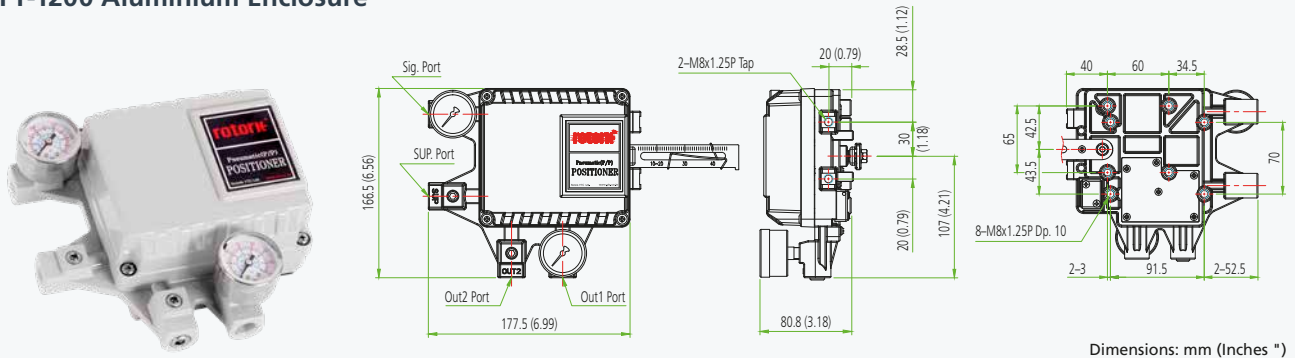

Dimensions: mm (Inches *)

Item Type	YT-1200L & YT-1200R	
	Single	Double
Input Signal	0.02 to 0.1 MPa / 0.2 to 1 bar / 3 to 14.5 psi	
Supply Pressure	0.14 to 0.7 MPa / 1.4 to 7 bar / 20 to 102 psi	
Stroke	Linear Type	10 to 150 mm (0.4 to 6")
	Rotary Type	55 to 100°
Air Connection	Rc ¼, ¼ NPT	
Gauge Connection	Rc 1/8, 1/8 NPT	
Ingress Protection	IP66	
Linearity	Linear Type	± 1% F.S.
	Rotary Type	± 2% F.S.
Hysteresis	±1% F.S.	
Sensitivity	Linear Type	± 0.2% F.S.
	Rotary Type	± 0.5% F.S.
Repeatability	± 0.5% F.S.	
Air Consumption	2.5 LPM (sup = 0.14 MPa) 0.08 CFM (sup = 20 psi)	
Flow Capacity	80 LPM (sup = 0.14 MPa) 2.83 CFM (sup = 20 psi)	
Material	Aluminium Diecasting	
Weight	1.7 kg (3.1 lb)	

Product Code

YT-1200R - S - 1 - 1 - 2 - S - (0)

Model

YT-1200L = Linear Positioner
YT-1200R = Rotary Positioner

Acting Type

S = Single
D = Double

Lever Type

Linear	Rotary
1 = 10 to 40 mm	1 = M6 x 34L
2 = 30 to 70 mm	2 = M6 x 63L
3 = 60 to 100 mm	3 = M8 x 34L
4 = 100 to 150 mm	4 = M8 x 63L
	5 = NAMUR

Orifice Type

1 = Ø1
2 = Ø2
3 = None

Air Connection

1 = Rc ¼
2 = ¼ NPT

Operating Temp.

S = -20 to +70 °C (-4 to +158 °F)
H = -20 to +120 °C (-4 to +248 °F)
L = -40 to +70 °C (-40 to +158 °F)

Option (Rotary only)

0 = None
1 = Dome Cover
2 = 4-20 mA feedback - SPTM-5V (Non-explosion)¹
3 = 4-20 mA feedback - SPTM-6V (Flameproof enclosure)¹
4 = Limit switch – YT-850 (Non-explosion)²
5 = Limit switch – YT-870 (Flameproof enclosure)²
6 = 4-20 mA feedback + Limit Switch – YT-870 (Flameproof enclosure)²

Notes:

1. Only S, L of Operating Temperature is available
2. Only S of Operating Temperature is available

Electro-Pneumatic Positioners YT-1000 / YT-1050

Design features

- **Simple zero and span adjustment.** Internal hand dials and locking screws for 4-20 mA range adjustments.
- **Reverse and direct acting settings.** Full and ½ split range setting by simple adjustment.
- **High vibration resistant.** No resonance between 5 to 200 Hz.
- **Internal feedback option.** Available on weatherproof model only.
- **Auto / manual switch.** Internal adjustment with lock screw safety.



YT-1000 Aluminium Enclosure

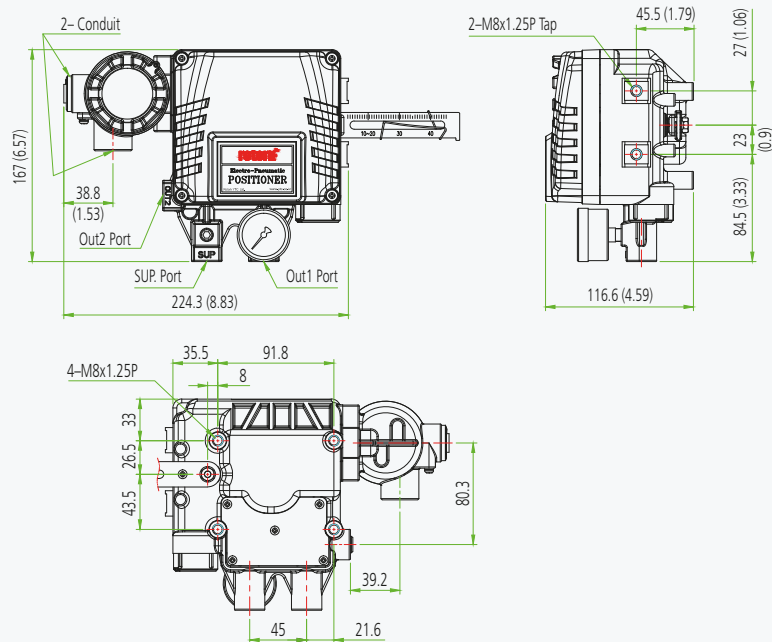

YT-1050 STS316 Enclosure

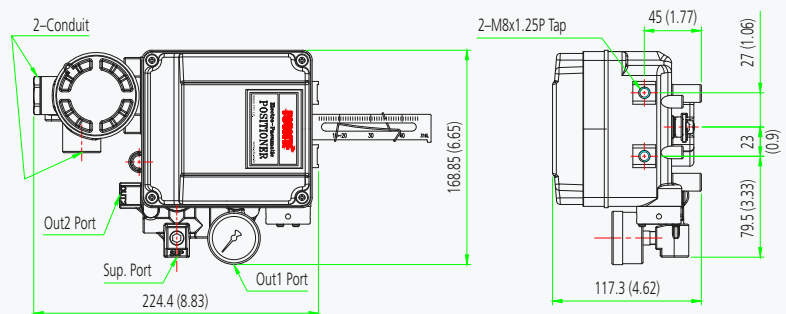

Dimensions: mm (Inches ")

Electro-Pneumatic Positioners YT-1000 / YT-1050

Item Type	YT-1000	YT-1050
Input Signal	4-20 mA DC	
Impedance	250 ± 15 Ω	
Supply Pressure	0.14 to 0.7 MPa = 1.4 to 7 bar = 20 to 102 psi	
Stroke	Linear Type	10 to 150 mm (0.4 to 6")
	Rotary Type	55 to 100°
Air Connection	Rc ¼, ¼ NPT, G ¼	¼ NPT
Gauge Connection	Rc ⅛, ⅛ NPT	⅛ NPT
Conduit	G(NPT) ½, M20	G ½
Explosion Protection Type	ATEX / IECEx (II 2 G) Ex dmb IIB T5, Ex ia IIC T6	
	EAC 1Ex dmb IIB T5	
	INMETRO (II 2 G) Ex dmb IIB T5	
	KCs Ex dmb IIB T5/T4 / Ex dmb IIC T5 / Ex ia IIB T6 Gb (pending)	KCs Ex dmb IIB T5
	TS Ex db mb IIB T5 Gb X	
	CSA (Class I, Zone 1) Ex dm IIB T5	
Explosion Protection Type	FM XP-S/II/1/CD/T5 Ta = +60 °C; DIP/II,III/1/EFG/T5 Ta = +60 °C; Type 4X	
	CCC Ex d mb IIB T5 Gb Ex d mb IIC T6 Gb Ex ia IIC T6 Ga	CCC Ex d mb IIB T5 Gb
	TIIS Ex dmb IIB T5	
Ingress Protection	YT-1000: IP66, TYPE 4X (FM) YT-1050: IP66	
Linearity	Single	± 1% F.S.
	Double	± 2% F.S.
Hysteresis	±1% F.S.	
Sensitivity	Single	± 0.2% F.S.
	Double	± 0.5% F.S.
Repeatability	± 0.5% F.S.	
Air Consumption	2.5 LPM (sup = 0.14 MPa) 0.8 CFM (sup = 20 psi)	
Flow Capacity	80 LPM (sup = 0.14 MPa) 2.83 CFM (sup = 20 psi)	
Material	Aluminium Diecasting	Stainless steel 316
Weight	YT-1000L: 2.7 kg (6.1 lb) YT-1000R: 2.8 kg (6.2 lb) YT-1050: 5.71 kg (12.6 lb)	

Product Code

YT-1000 - R - S - N - 1 - 1 - 4 - S - 0 - (0)

Model

YT-1000 = Aluminium
YT-1050 = STS316

Motion Type

L = Linear
R = Rotary

Acting Type

S = Single
D = Double

Explosion Protection¹

N = Non-Explosionproof
M² = Ex d m IIB, ATEX, IECEx,
TS (YT-1000 only), KCs
A² = CSA (YT-1000 only)
C = Ex dmb IIC T5 KCs
(YT-1000 only)
E = Ex d EAC
X² = TIIS (YT-1000 only)
i = Ex ia IIC T6 Gb, ATEX/
IECEx, KCs (YT-1000 only)

T = Ex dm IIB INMETRO
Z = Ex d mb IIB T5 Gb CCC
B = Ex d mb IIC T6 Gb:CCC
(YT-1000 only)
G = Ex ia IIC T6 Gb CCC
(YT-1000 only)
F = FM (YT-1000 only)
P = Ex ia IIC T6, NEPSI
(YT-1000 only)

Lever Type

Linear	Rotary
1 = 10 to 40 mm	1 = M6 X 34L
2 = 30 to 70 mm	2 = M6 X 63L
3 = 60 to 100 mm	3 = M8 X 34L
4 = 100 to 150 mm	4 = M8 X 63L
	5 = NAMUR

Orifice Type

1 = Φ1
2 = Φ2
3 = None

Conduit & Air Connection

YT-1000	YT-1050
1 = G ½ - Rc ¼	2 = G ½ - ¼ NPT
2 = G ½ - ¼ NPT	(N/A for CCC)
3 = G ½ - G¼	5 = ½ NPT - ¼ NPT
4 = M20 - ¼ NPT	(CCC only)
5 = ½ NPT - ¼ NPT	

Operating Temp. (Non-explosionproof)³

S = -20 to +70 °C (-4 to +158 °F)
H = -20 to +120 °C (-4 to +248 °F)
L = -40 to +70 °C (-40 to +158 °F)

Option 1

YT-1000L	YT-1000R
0 = None	0 = None (St'd)
2 ⁴ = 4-20 mA feedback (Internal)	1 = Dome Cover
3 ⁴ = 4-20 mA feedback with LCD (Internal)	

Option 2 (YT-1000R only)

0 = None
1 = 4-20 mA feedback (Internal - only for non-explosion area protection)
2 = 4-20 mA feedback (External, SPTM-6V, Explosionproof)
3 = Limit Switch (Internal - only for non-explosion area protection)
4 = Limit Switch (External, YT-850 (Non-explosion) or YT-870 (Explosionproof))
5 = 4-20 mA feedback + Limit Switch (Internal - only for non-explosion area protection)
6 = SPTM + Limit Switch (External, YT-870, Explosionproof)

Notes:

1. Only S of Operating Temperature is available for M (except KCs of YT-1000), T, F, H, P, X
Only S, H of Operating Temperature are available for M (only KCs of YT-1000)
Only S, L of Operating Temperature are available for A and C
Only L of Operating Temperature is available for E.
2. Please put the name of the certificate in a purchase order.
3. This option is just the normal operating temperature of the product and is not related to explosion protection temperature. See certificates for explosion protection temperature.
4. Non-explosionproof.

Compact Smart Positioner YT-3100

Design features

- **Compact.** Reliable and precise Smart Positioner, for linear and quarter-turn rotary actuators. Both single- and double-acting layouts are available.
- **Gauge manifold.** An option to keep the unit as compact as possible when gauges are not required.
- **Smart management system.** A clear and easy to navigate menu with four push buttons.
- **Visual self diagnostic.** Rated to NE107 standard for a user friendly and simplified troubleshooting process.
- **Position feedback.** 4-20 mA analogue completes the package, assuring full process control.
- **Non-contact sensor** for increased performance for high frequency operating valves and an enhanced lifetime.



YT-3100 Aluminium Enclosure With Polycarbonate Cover

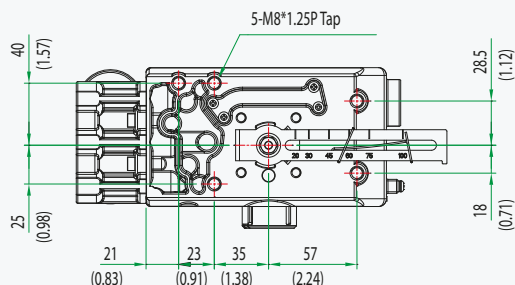
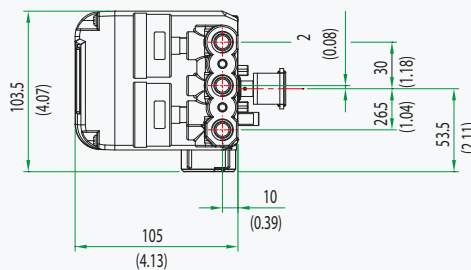
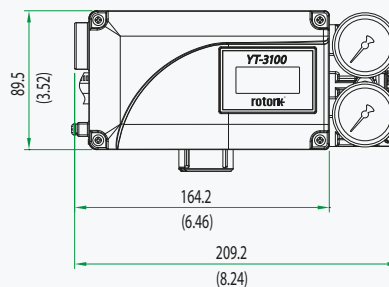

Dimensions: mm (Inches ")

Compact Smart Positioner YT-3100

Item Type	YT-3100	
Input Signal	4 to 20 mA DC	
Supply Pressure	0.14 to 0.7 MPa = 1.4 to 7 bar = 20 to 102 psi	
Stroke	Linear Type	10 to 150 mm (0.4 to 6")
	Rotary Type	55 to 110°
Impedance	Max. 500 Ω @ 20 mA DC	
Air Connection	Rc ¼, ¼ NPT	
Gauge Connection	Rc ⅛, ⅛ NPT	
Conduit	G ½	
Operating Temp.	-30 to +85 °C (-22 to +185 °F)	
Linearity	±0.5% F.S.	
Hysteresis	±0.5% F.S.	
Sensitivity	±0.2% F.S.	
Repeatability	±0.3% F.S.	
Air Consumption	Below 2 LPM (sup = 0.14 MPa) Below 0.07 CFM (sup = 20 psi)	
Flow Capacity	70 LPM (sup = 0.14 MPa) 2.47 CFM (sup = 20 psi)	
Output Characteristics	Linear, EQ%, Quick Open, User Set	
Material	Housing: Aluminium Diecasting Cover: Polycarbonate	
Ingress Protection	IP66	
Explosion Protection Type	ATEX, IECEx Ex ia IIC T5/T6 Gb KCs Ex ia IIC T5/T6 CCC, NEPSI Ex ia IIC T5/T6 Gb Ambient temp: -30 to +60 °C (T5) / -30 to +40 °C (T6)	
Weight	1.7 kg (3.7 lb)	

Product Code

YT-3100 - L - S - N - 2 - 1 - 1 - 1 - S

Model

YT-3100 = Aluminium housing
and Polycarbonate cover

Motion Type

L = Linear
R = Rotary

Acting Type

S = Single
D = Double

Explosion Protection

N = Safe Area
I = Intrinsically Safe KCs, ATEX, IECEx, NEPSI
Z = Intrinsically Safe CCC

Lever Type

Linear	Rotary
0 = 10 to 40 mm	5 = NAMUR
1 = 20 to 100 mm	
2 = 90 to 150 mm	

Conduit & Air Connection

1 = G ½ - Rc ¼
2 = G ½ - ¼ NPT

Gauges Block

0 = NONE
1 = Gauges block

Options

0 = NONE
1 = PTM 4-20 mA feedback

Operating Temp.

S = -30 to +85 °C (-22 to +185 °F)

Smart Positioners YT-3300 / YT-3350

Torque motor technology with communications

Design features

- **Auto calibration.** Simple menu structure with options to auto calibrate all parameters or zero and end points only.
- **LCD display.** Alphanumeric digital display for process values and calibration.
- **Partial Stroke Test (PST).** Fully adjustable Partial Stroke Test. All functionality can be performed and selected locally, through push buttons, or remotely with communication protocol.
- **Feedback signal.** Analogue and digital feedback signals with 4-20 mA, mechanical and proximity switch options.
- **PID control.** Pre-calibrated and user-configurable variables via front panel pushbutton menu.
- **Auto / Manual switch.** Enables closed-loop automatic valve position control or manual positioning via the A/M switch. The manual mode is useful for troubleshooting, calibration, system testing or as a manual bypass.
- **HART® communication.** Allows commands, position feedback and diagnostics to be sent digitally over the current loop.
- **NEW Profibus Process Automation (PA).** Manages equipment via a process control system in process automation applications. The PA variant is designed for use in hazardous areas (Ex zones 0 and 1). The Physical Layer, with over the bus power, limits current flows so that

explosive conditions are not created, even if a malfunction occurs. The number of devices attached to a PA segment is limited by this feature. However, PA uses the same protocol as DP, and can be linked to a DP network using a coupler device. The much faster DP acts as a backbone network for transmitting process signals to the controller. This means that DP and PA can work tightly together, especially in hybrid applications where process and factory automation networks operate side by side.

- **NEW Foundation Fieldbus.** A bi-directional communications protocol used for communications among field devices and the control system. It utilizes twisted pair or fibre media to communicate between multiple nodes (devices) and the controller. The controller requires only one communication point to communicate with up to 32 nodes, this is a significant improvement over the standard 4-20 mA communication method which requires a separate connection point for each communication device on the controller system.
- **Front panel pushbuttons for configuration.** Four robust and positive acting pushbuttons for field configuration.
- **Non-contact sensor** for increased performance for high frequency operating valves and an enhanced lifetime.



YT-3300 Aluminium Enclosure

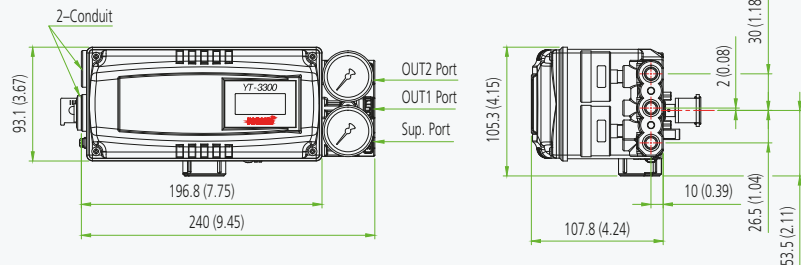

YT-3350 STS316 Enclosure

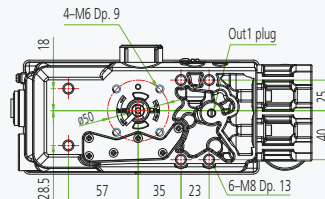

Dimensions: mm (Inches ")

Smart Positioners YT-3300 / YT-3350

Item Type		YT-3300	YT-3350
Input Signal		4-20 mA DC	
Supply Pressure		0.14 to 0.7 MPa / 1.4 to 7 bar / 20 to 102 psi	
Stroke	Linear Type	10 to 150 mm (0.4 to 6")	
	Rotary Type	55 to 110°	
Impedance		Max. 500 Ω @ 20 mA DC	
Air Connection		Rc ¼, ¼ NPT, G ¼	¼ NPT
Gauge Connection		Rc ⅛, ⅛ NPT	⅛ NPT
Conduit		G ½, M20, ½ NPT	G ½
Operating Temp.	Standard Type	-30 to +85 °C (-22 to +185 °F)	
	Low Temp. Type	-40 to +85 °C (-40 to +185 °F)	
	Arctic Type	-55 to +85 °C (-67 to +185 °F)	
	LCD	withstands -55 to +85 °C (-67 to +185 °F) only visible above -40 °C (-40 °F)	
Linearity		±0.5% F.S.	
Hysteresis		±0.5% F.S.	
Sensitivity		±0.2% F.S.	
Repeatability		±0.3% F.S.	
Air Consumption		Below 2 LPM (sup = 0.14 Mpa) Below 0.07 CFM (sup = 20 psi)	
Flow Capacity		70 LPM (sup = 0.14 MPa) 2.47 CFM (sup = 20 psi)	
Output Characteristics		Linear, EQ%, Quick Open, User Set (5, 21 Points)	
Material		Aluminium Diecasting	Stainless Steel 316
Ingress Protection		NEMA 4X, IP66	
Explosion Protection Type	ATEX / IECEx / EAC Ex ia IIC T5/T6 Gb Ex ia IIIC T100°C/T85°C Db IP66		
	CCC Ex ia IIC T5/T6 Gb Ex iaD 21 T1 00/T85		
	KCs Ex ia IIC T6/T5 Ex ia IIIC T85°C/T100°C		
	CSA CSA certificate		
	FM Class I, Div 1, Groups A, B, C & D Class I, Zone 0 Aex ia IIC Class II/III, Div 1, Groups E, F & G Class I/II/III, Div 2, Groups A, B, C, D, E, F & G NEMA Type 4X, IP66, IP54 Ambient temp: -40 to +60°C (T5) / -40 to +40°C (T6)		
	NEPSI Ex ia IIC T5/T6		
	INMETRO Ex ia IIC T5/T6 Gb Ex ia IIIC T100°C/T85°C Db		
	HART (ver.7) Profibus PA ¹ Foundation Fieldbus ¹		
	Communication (Option)		
	L/S Rating	Mechanical Type (Omron)	125 VAC, 3 A / 30 VDC, 2 A
	Proximity Type (P&F)	8.2 VDC, 8.2 mA	
Weight		2 kg (4.4 lb)	5.1 kg (11.2 lb)

Product Code

YT-3300 - L - S - N - 2 - 4 - 2 - 4 - S

Model

YT-3300 = Aluminium housing
YT-3350 = Stainless steel housing

Motion Type

L = Linear
R = Rotary

Acting Type

S = Single
D = Double

Explosion Protection

N = Non-explosion
i = Intrinsically Safe ATEX, IECEx, NEPSI, KCs, INMETRO, PESO
E = Intrinsically Safe EAC
A = Intrinsically Safe CSA, FM
AG = Intrinsically Safe CSA, FM - Tapped Exhaust
Z = Intrinsically Safe CCC

Lever Type

Linear		Rotary
0 = 10 to 40 mm	standard type adapter	1 = M6 x 34L
1 = 20 to 100 mm		2 = M6 x 63L
2 = 90 to 150 mm		3 = M8 x 34L
3 = 16 to 30 mm		4 = M8 x 63L
4 = 16 to 60 mm		5 = NAMUR
5 = 16 to 100 mm		
6 = 90 to 150 mm		fork type

Conduit & Air Connection

1 = G ½ - Rc ¼ (N/A for YT-3350)
2 = G ½ - ¼ NPT
3 = G ½ - G ¼ (N/A for YT-3350)
4 = M20 - ¼ NPT (N/A for YT-3350)
5 = ½ NPT - ¼ NPT (N/A for YT-3350)

Communications

0 = None
2 = HART protocol communication
3 = Profibus PA¹
4 = Foundation Fieldbus¹

Output Options

0 = None
1 = 4 to 20 mA feedback
2² = Limit Switch - Mechanical Type
3³ = Limit Switch - Proximity Type
4² = 4 to 20 mA + Limit Switch - Mechanical Type
5³ = 4 to 20 mA + Limit Switch - Proximity Type

Operating Temp. (Non-explosionproof)⁴

S = -30 to +85 °C (-22 to +185 °F) (N/A for EAC)
L = -40 to +85 °C (-40 to +185 °F)
A = -55 to +85 °C (-67 to +185 °F) (EAC only)

Notes:

1. Only available to ATEX/IECEx and Output Option code 0. Potentiometer feedback sensor is only applicable. Arctic temperature option is not available.
2. Only S, L of Operating Temperature are available for 2, 4 of Output Options. This option is only available with potentiometer feedback sensor.
3. Only S of Operating Temperature is available for 3, 5 of Output Options. This option is only available with potentiometer feedback sensor.
4. This option is just the normal operating temperature of the product and is not related to explosion protection temperature. See certificates for explosion protection temperature.

Smart Positioners YT-3301 / YT-3302 / YT-3303

Torque motor technology with communications

Design features

- **Auto calibration.** Simple menu structure with options to auto calibrate all parameters or zero and end points only.
- **LCD display.** Alphanumeric digital display for process values and calibration.
- **Partial Stroke Test (PST).** Fully adjustable Partial Stroke Test. All functionality can be performed and selected locally, through push buttons, or remotely with communication protocol.
- **Feedback signal.** Analogue 4-20 mA position feedback option.
- **PID control.** Pre-calibrated and user-configurable variables via front panel pushbutton menu.
- **Auto / Manual switch.** Enables closed-loop automatic valve position control or manual positioning via the A/M switch. The manual mode is useful for troubleshooting, calibration, system testing or as a manual bypass.
- **HART® communication.** Allows commands, position feedback and diagnostics to be sent digitally over the current loop.
- **Front panel pushbuttons for configuration.** Four robust and positive acting pushbuttons for field configuration.
- **Remote Mounting Option (YT-3301/YT-3302).** Remote sensor via cable to enable the positioner to be mounted away from extreme temperature.



YT-3301 Remote Mounting Option

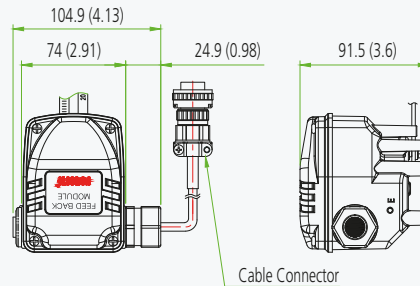

YT-3302 Remote Mounting Option

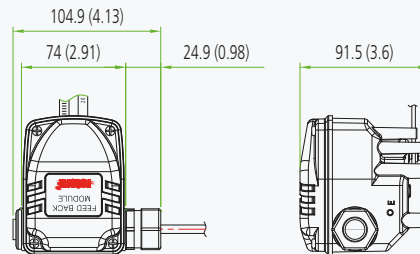

YT-3303 Left Side Mounting Option

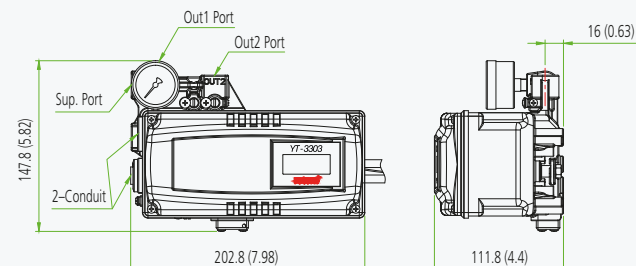

Dimensions: mm (Inches ")

Smart Positioners YT-3301 / YT-3302 / YT-3303

Item Type	YT-3301 / 3302	YT-3303	
Input Signal	4-20 mA DC		
Supply Pressure	0.14 to 0.7 MPa / 1.4 to 7 bar / 20 to 102 psi		
Stroke	Linear Type	10 to 150 mm (0.4 to 6")	
	Rotary Type	55 to 110°	
Impedance	Max. 500 Ω @ 20 mA DC		
Air Connection	Rc ¼, ¼ NPT, G ¼		
Gauge Connection	Rc ⅛, ⅛ NPT		
Conduit	G ½, M20, ½ NPT		
Operating Temp.	Standard Type	-30 to +85 °C (-22 to +185 °F)	
	Low Temp. Type	-40 to +85 °C (-40 to +185 °F)	
	Arctic Temp. Type	-55 to +85 °C (-67 to +185 °F)	
	LCD	withstands -55 to +85 °C (-67 to +185 °F) only visible above -40 °C (-40 °F)	
Linearity	±0.5% F.S.		
Hysteresis	±0.5% F.S.		
Sensitivity	±0.2% F.S.		
Repeatability	±0.3% F.S.		
Air Consumption	Below 2 LPM (sup = 0.14 Mpa) Below 0.07 CFM (sup = 20 psi)		
Flow Capacity	70 LPM (sup = 0.14 MPa) 2.47 CFM (sup = 20 psi)		
Output Characteristics	Linear, EQ%, Quick Open, User Set (5, 18 Points)		
Material	Aluminium Diecasting		
Ingress Protection	IP66, IP54 (YT-3301) IP66 (YT-3302)	IP66	
Explosion Protection Type	ATEX / IECEx Ex ia IIC T5/T6 Gb Ex ia IIIC T100°C/T85°C Db IP66		
	CCC Ex ia IIC T5/T6 Gb Ex iaD 21 T100°C/T85°C		
	KCs Ex ia IIC T6/T5 Ex ia IIIC T85°C/T100°C		
	CSA CSA certificate		
	FM Class I, Div 1, Groups A, B, C & D Class I, Zone 0 Aex ia IIC Class II/III, Div 1, Groups E, F & G Class I/II/III, Div 2, Groups A, B, C, D, F & G NEMA Type 4X, IP66, IP54 Ambient temp: -40 to +60°C (T5) / -40 to +40°C (T6)		
	EAC 1Ex ia IIC T6/T5 Ex ia IIIC T85/T100		
	INMETRO Ex ia IIC T6/T5 Gb Ex ia IIC T85°C/T100°C Db		
	Communication (Option)		HART (ver.7)
	Weight	Body	2.2 kg (4.9 lb) / 2.5 kg (5.5 lb)
		Remote Sensor	1 kg (2.1 lb)
		2 kg (4.4 lb)	
		-	

Product Code

YT-3301 - L - S - N - 2 - 4 - 2 - 1 - S - (1)

Model

YT-3301 = Aluminium housing with remote sensor
YT-3302 = Aluminium housing with remote sensor
YT-3303 = Aluminium housing with right side lever

Motion Type

L = Linear
R = Rotary

Acting Type

S = Single
D = Double

Explosion Protection

N = Non-explosion
i = Intrinsically Safe ATEX, IECEx, KCs, INMETRO
E = Intrinsically Safe EAC
A = Intrinsically Safe CSA, FM
AG = Intrinsically Safe CSA, FM - Tapped Exhaust
Z = Intrinsically Safe CCC

Lever Type

Linear	Rotary	
1 = 10 to 40 mm	1 = M6 X 34L (YT-3303 only)	fork type
2 = 20 to 70 mm	2 = M6 X 63L (YT-3303 only)	
3 = 50 to 100 mm	3 = M8 X 34L (YT-3303 only)	
4 = 100 to 150 mm	4 = M8 X 63L (YT-3303 only)	
	5 = NAMUR (YT-3301/3302/3303)	

Conduit & Air Connection

1 = G ½ - Rc ¼
2 = G ½ - ¼ NPT
3 = G ½ - G ¼
4 = M20 - ¼ NPT
5 = ½ NPT - ¼ NPT

Communications

0 = None
2 = HART protocol communication

Output Options

0 = None
1 = 4 to 20 mA feedback

Operating Temp. (Non-explosionproof)¹

S = -30 to +85 °C (-22 to +185 °F) (N/A for EAC)
L = -40 to +85 °C (-40 to +185 °F)
A = -55 to +85 °C (-67 to +185 °F) (EAC only)

Cable Length (YT-3301/3302 only)

Standard cable length is 5 m.
1 = 5 m
2 = 10 m
3 = 15 m
4 = 20 m

Notes:

1. This option is just the normal operating temperature of the product and is not related to explosion protection temperature. See certificates for explosion protection temperature.

Smart Positioners YT-3700 / YT3702 / YT-3750

Digital smart positioner with enhanced diagnostics

Design features

- **Enhanced diagnostic** (including offline and online) to fully check the integrity of the system. Valve signature, advanced step tests and Partial Stroke Testing (PST) can be operated from local or remote positions. Device Description (DD) and Device Type Manager (DTM) files allow for full software compatibility.
- **Visual diagnostic info** to NE107 standard for a user-friendly analysis with a severity alarm scale and a clear visual identification locally on the display or remotely through HART®.

- **Digital input/output configurable** depending on the application and customer preferences. Multiple options are available e.g. start a pre-set PST event or receive error alarms, tailoring interaction with the device as necessary.
- **Auto tuning** functionality.
- **Non-contact sensor** for increased performance for high frequency operating valves and an enhanced lifetime.



YT-3700 Aluminium Enclosure

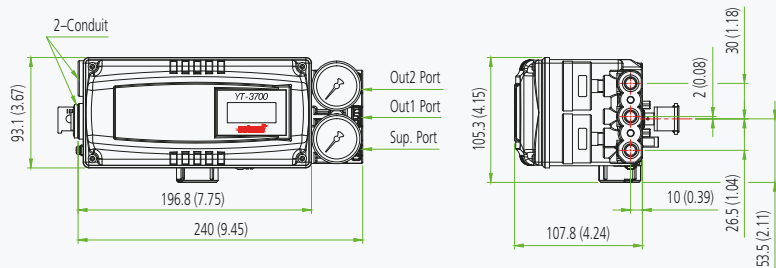

YT-3700 Aluminium Enclosure With Limit Switches and Dome Indicator

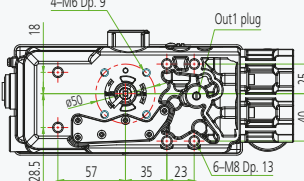

YT-3702 Remote Mounting Option

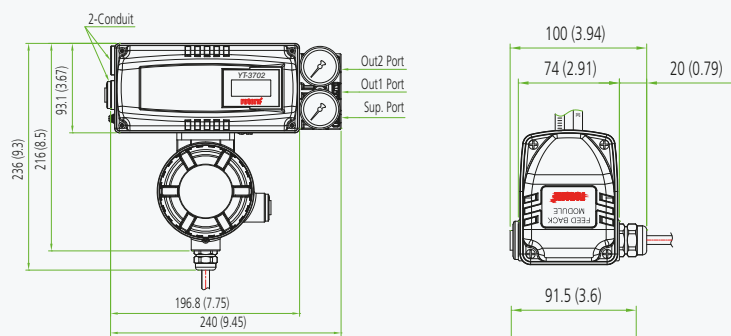

YT-3750 STS316 Enclosure

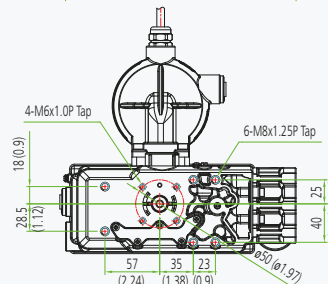

Dimensions: mm (Inches ")

Smart Positioners YT-3700 / YT3702 / YT-3750

Item Type	YT-3700 / 3702	YT-3750
Input Signal	4-20 mA DC	
Supply Pressure	0.14 to 0.7 MPa = 1.4 to 7 bar = 20 to 102 psi	
Stroke	Linear Type	10 to 150 mm (0.4 to 6")
	Rotary Type	55 to 110°
Impedance	Max. 500 Ω @ 20 mA DC	
Air Connection	Rc ¼, ¼ NPT, G ¼	¼ NPT
Gauge Connection	Rc 1/8, 1/8 NPT	1/8 NPT
Conduit	G ½, M20, ½ NPT	G ½
Operating Temp.	Standard Type	-30 to +85 °C (-22 to +185 °F)
	Low Temp. Type	-40 to +85 °C (-40 to +185 °F)
	Arctic Temp. Type	-55 to +85 °C (-67 to +185 °F)
	LCD	withstands -55 to +85 °C (-67 to +185 °F) only visible above -40 °C (-40 °F)
	Remote NCS	-55 to +125 °C (-67 to +257 °F)
Linearity	±0.5% F.S.	
Hysteresis	±0.5% F.S.	
Sensitivity	±0.2% F.S.	
Repeatability	±0.3% F.S.	
Air Consumption	Below 2 LPM (sup = 0.14 Mpa) Below 0.07 CFM (sup = 20 psi)	
Flow Capacity	70 LPM (sup = 0.14 MPa) 2.47 CFM (sup = 20 psi)	
Output Characteristics	Linear, EQ%, Quick Open, User Set (5, 21 points)	
Material	Aluminium Diecasting	Stainless Steel 316
Ingress Protection	IP66, NEMA 4X	
Explosion Protection Type	ATEX / IECEx Ex ia IIC T5/T6 Gb Ex ia IIIC T100°C/T85°C Db IP 6x	
	CCC / Nepsi Ex ia IIC T5/T6 Gb Ex iaD 21 T100°C/T85°C	
	FM / CSA / EAC Intrinsically Safe. Refer to the product manual for details.	
	KCs Ex ia IIC T5/T6 Gb Ex ia IIIC T100°C/T85°C	
	INMETRO Ex ia IIC T5/T6 Gb Ex ia IIC T100°C/T85°C Db IP66	
	SIL SIL2 and SIL3 Non-interference device statement for SIS	
	Communication (Option)	
L/S	Mechanical Type (Omron) AC 125 V, 3 A / DC 30 V, 2 A (YT-3702 is not available)	
Rating	Proximity Type (P&F) DC 8.2 V 8.2 mA (YT-3702 is not available)	
Weight	2 kg (4.4 lb) / 2.9 kg (6.4 lb)	5.1 kg (11.2 lb)
Digital Input	Low level control voltage 0 to 5 VDC High level control voltage 11 to 28 VDC Max current < 4 mA	
Digital Output	Supply voltage 5 to 28 VDC Low level current < 1 mA High level current > 2.1 mA @5 VDC, < 14mA @28 VDC	

Product Code

YT-3700 - L - S - N - 2 - 4 - 2 - 4 - S - (1)

Model

YT-3700 = Aluminium housing
YT-3702 = Aluminium housing with remote NCS
YT-3750 = Stainless steel housing

Motion Type

L = Linear
R = Rotary (in case of a switches request the device will have visual position indicator as standard)

Acting Type

S = Single
D = Double

Explosion Protection

N = Non-explosion (YT-3702 is N only)
i = Intrinsically Safe ATEX, IECEx. NEPSI, KCs
A = Intrinsically Safe CSA, FM (Both S and L of Operating Temp. available)
AG = Intrinsically Safe CSA, FM - Tapped Exhaust
E = Intrinsically Safe EAC
Z = Intrinsically Safe CCC

Lever Type

Linear Rotary
0 = 10 to 40 mm (YT-3700/3750) 5 = NAMUR
1 = 20 to 100 mm (YT-3700/3750)
2 = 90 to 150 mm (YT-3700/3750)
1 = 10 to 40 mm (YT-3702 only)
2 = 20 to 70 mm (YT-3702 only)
3 = 50 to 100 mm (YT-3702 only)
4 = 100 to 150 mm (YT-3702 only)

Conduit & Air Connection

1 = G ½ - Rc ¼ (N/A for YT-3750)
2 = G ½ - ¼ NPT
3 = G ½ - G ¼ (N/A for YT-3750)
4 = M20 - ¼ NPT (N/A for YT-3750)
5 = ½ NPT - ¼ NPT (N/A for YT-3750)

Communication Protocols

2 = HART communication

Output Options

0 = None (Digital I/O are built-in)
1 = 4-20 mA feedback (Digital I/O are built-in)
4¹ = 4-20 mA feedback + Limit Switch - Mechanical Type (potentiometer drive without digital I/O communication)
5² = 4-20 mA feedback + Limit Switch - Proximity Type (potentiometer drive without digital I/O communication)

Operating Temp. (Non-explosion proof)³

S = -30 to +85 °C (-22 to +185 °F) (N/A for EAC)
L = -40 to +85 °C (-40 to +185 °F)
A = -55 to +85 °C (-67 to +185 °F) (EAC only)

Cable Length (YT-3702 only)

Standard cable length is 5 m.
1 = 5 m
2 = 10 m
3 = 15 m
4 = 20 m

Notes:

- Only S, L of Operating Temperature are available for 4 of Output Options. This option is only available with potentiometer feedback sensor.
- Only S of Operating Temperature is available for 5 of Output Options. This option is only available with potentiometer feedback sensor.
- This option is just the normal operating temperature of the product and is not related to explosion protection temperature. See certificates for explosion protection temperature.

Smart Positioners YT-3400 / YT-3450

Torque motor technology with communications

Design features

- NEW **Enhanced diagnostic** (including offline and online) to fully check the integrity of the system. Valve signature, advanced step tests and Partial Stroke Testing (PST) can be operated from local or remote positions. Device Description (DD) and Device Type Manager (DTM) files allow for full software compatibility.
- Visual diagnostic info** to NE107 standard for a user-friendly analysis with a severity alarm scale and a clear visual identification locally on the display or remotely through HART®.

- Digital input/output configurable** depending on the application and customer preferences. Multiple options are available e.g. start a pre-set PST event or receive error alarms, tailoring interaction with the device as necessary.
- Auto tuning** functionality.
- Non-contact sensor** for increased performance for high frequency operating valves and an enhanced lifetime.



YT-3400 Aluminium Enclosure

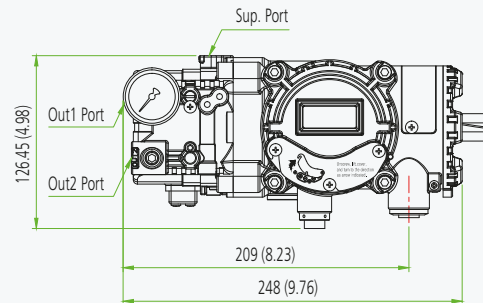

YT-3450 STS316 Enclosure

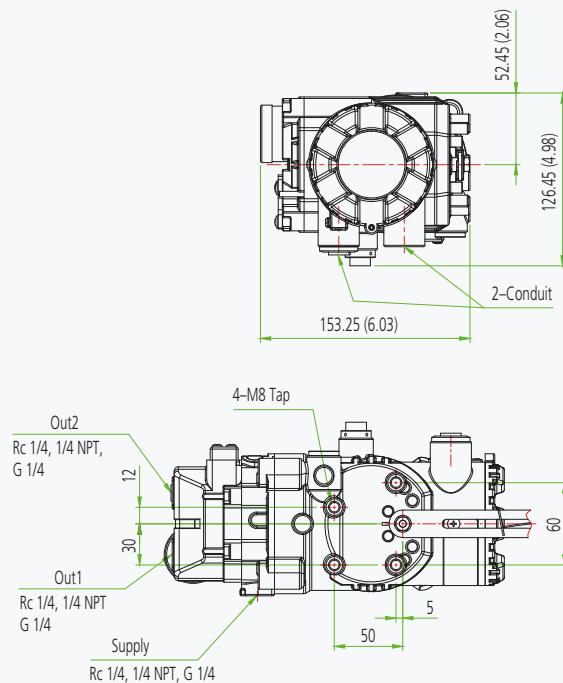

Dimensions: mm (Inches ")

Smart Positioners YT-3400 / YT-3450

Item Type	YT-3400	YT-3450
Input Signal	4-20 mA DC	
Supply Pressure	0.14 to 0.7 MPa / 1.4 to 7 bar / 20 to 102 psi	
Stroke	Linear Type	10 to 150 mm (0.4 to 6")
	Rotary Type	55 to 110°
Impedance	Max. 450 Ω @ 20 mA DC	
Air Connection	Rc ¼, ⅜ NPT, G ¼	¼ NPT
Gauge Connection	Rc ⅜, ½ NPT	⅜ NPT
Conduit	G ½, ½ NPT, M20	G ½
Operating Temp.	Standard Type	-30 to +85 °C (-22 to +185 °F)
	Low Temp. Type	-40 to +85 °C (-40 to +185 °F)
	Arctic Temp. Type*	-55 to +85 °C (-67 to +185 °F)
	LCD Operating Temp.	withstands -55 to +85 °C (-67 to +185 °F) only visible above -40 °C (-40 °F)
Linearity	±0.5% F.S.	
Hysteresis	±0.5% F.S.	
Sensitivity	±0.2% F.S.	
Repeatability	±0.3% F.S.	
Air Consumption	Below 2 LPM (sup = 0.14 MPa) Below 0.08 CFM (sup = 20 psi)	
Flow Capacity	70 LPM (sup = 0.14 MPa) 2.47 CFM (sup = 20 psi)	
Output Characteristics	Linear, EQ%, Quick Open, User Set (5 or 21 Points)	
Material	Aluminium Diecasting	Stainless Steel 316
Ingress Protection	NEMA 4-4X, IP66	
Explosion Protection Type	ATEX / IECEx / EAC Ex db IIC T5/T6 Ex tb IIIC T100°C/T85°C	
	CCC / NEPSI Ex d IIC T5/T6 Gb Ex tD A21 IP66 T100°C/T85°C	
	KCs Ex d IIC T5/T6 IP66	
	CSA Ex db IIC T5 or T6 Class I, Zone 1, AEx db IIC T5 or T6, Class II, Division 1, Groups E, F and G; Ex tb IIC T100°C/T85°C AEx tb IIIC T100°C/T85°C Type 4, 4X ; IP66	
	FM XP/II/ABCD/T6 Ta= -40°C to +70°C, T5 Ta= -40°C to +80°C I/IAEx db/IIC/T6 Ta= -40°C to +70°C, T5 Ta= -40°C to +80°C DIP/II, III/1/EF/G/T6 Ta= -40°C to +70°C, T5 Ta= -40°C to +80°C 21/AEx tb/IIIC/T85°C Ta= -40°C to +70°C, T100°C Ta= -40°C to +80°C; IP66	
	ECAS Ex db IIC T5/T6 Gb Ex tb IIIC T100°C/T85°C Db	
INMETRO Ex db IIC T5/T6 Gb IP66 Ex tb IIIC T100°C/T85°C Db IP66		
Communication (Option)	HART (ver.7)	
Weight	3.4 kg (7.5 lb)	7.0 kg (15.4 lb)

Product Code

YT-3400 - L - S - C - 2 - 4 - 2 - 3 - S

Model

YT-3400 = Aluminium housing
YT-3450 = Stainless steel housing

Motion Type

L = Linear
R = Rotary

Acting Type

S = Single
D = Double

Explosion Protection

C¹ = ATEX, IECEx, NEPSI, KCs, INMETRO
E = EAC
A = CSA, FM
AG = CSA, FM - Tapped Exhaust
Z = CCC

Lever Type

Linear	Rotary
1 = 10 to 40 mm	1 = M6 x 34L
2 = 20 to 70 mm	2 = M6 x 63L
3 = 50 to 100 mm	3 = M8 x 34L
4 = 100 to 150 mm	4 = M8 x 63L
	5 = NAMUR

Conduit & Air Connection

1 = G ½ - Rc ¼ (N/A for FM and CCC or YT-3450)
2 = G ½ - ¼ NPT (N/A for FM and CCC)
3 = G ½ - G ¼ (N/A for FM and CCC or YT-3450)
4 = M20 - ¼ NPT (N/A for YT-3450)
5 = ½ NPT - ¼ NPT (N/A for YT-3450)

Communication

0 = None
2 = HART protocol communication
5 = HART with Enhanced Diagnostic Capabilities & DI/DO

Output Options⁴

0 = None
1 = 4-20 mA feedback
2 = Limit switch²
3 = 4-20 mA feedback + Limit switch²

Operating Temp. (Non-explosion proof)³

S = -30 to +80 °C (-22 to +176 °F) (N/A for EAC)
L = -40 to +80 °C (-40 to +176 °F)
A* = -55 to +80 °C (-67 to +176 °F) (EAC only)

Notes:

- Please put the name of the certificate in a purchase order.
- Limit Switch (or Digital Output): DC 24V (50mA) and transistor type.
- This option is just the normal operating temperature of the product and is not related to explosion protection temperature.
See certificates for explosion protection temperature.
* Arctic temperature range for double acting devices is -52 to +85 °C (-62 to +185 °F).
- Output Options 2 and 3 are not selectable when Communication option 5 is selected. Communication option 5 includes digital I/O and digital output is configurable to software limit switch.

Smart Positioners YT-2500 / YT-2550 / YT-2501

Piezo technology with communications

Design features

- **Fail-freeze and fail-safe functions.** Enables the valve to maintain the last position (fail-freeze) or move to a pre-determined position (fail-safe) on the loss of electrical power supply or the pneumatic supply air.
- **Auto calibration.** Simple menu structure with options to auto calibrate all parameters or zero and end points only.
- **LCD display.** Alphanumeric digital display for process values and calibration.
- **Low air consumption level.** Almost zero air leakage.
- **Feedback signal.** Analogue feedback signals with 4-20 mA, mechanical and proximity switch options.
- **PD control.** Pre-calibrated and user-configurable variables via front panel pushbutton menu.
- **HART® communication.** Allows commands, position feedback and diagnostics to be sent digitally over the current loop.
- **Front panel pushbuttons for configuration.** Four robust and positive acting pushbuttons for field configuration.



YT-2500 Aluminium Enclosure

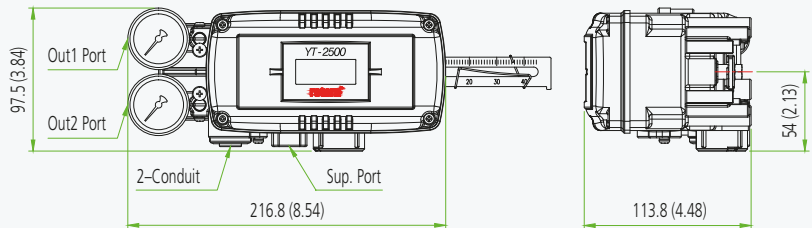

YT-2550 Stainless Steel Enclosure

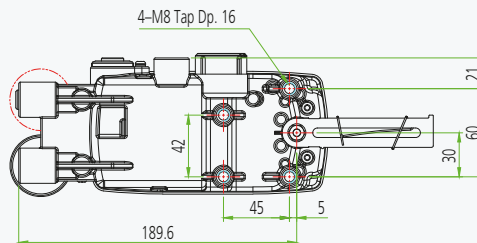

YT-2501 Remote Mounting Option

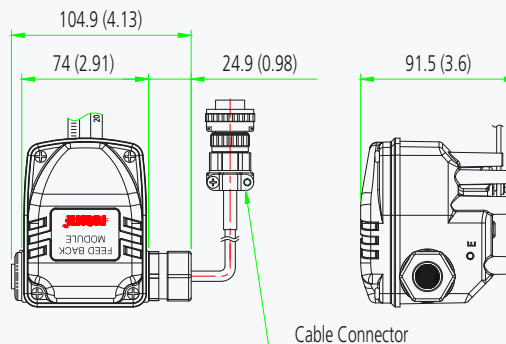

Dimensions: mm (Inches ")

Smart Positioners YT-2500 / YT-2550 / YT-2501

Item Type		YT-2500	YT-2550	YT-2501
Input Signal		4-20 mA DC		
Supply Pressure		0.14 to 0.7 MPa = 1.4 to 7 bar = 20 to 102 psi		
Stroke	Linear Type	10 to 150 mm (0.4 to 6")		
	Rotary Type	55 to 110°		
Impedance		Max. 500 Ω @ 20 mA DC		
Air Connection		Rc 1/4, 1/4 NPT, G 1/4	1/4 NPT	Rc 1/4, 1/4 NPT, G 1/4
Gauge Connection		Rc 1/8, 1/8 NPT	1 1/8 NPT	Rc 1/8, 1/8 NPT
Conduit		G 1/2, 1/2 NPT, M20x1.5P	G 1/2	G 1/2, 1/2 NPT, M20x1.5P
Operating Temp.	Standard Type	-30 to +80 °C (-22 to +176 °F) ¹		
	Explosion Temp.	-30 to +60 °C (-22 to +140 °F) (T5) -30 to +40 °C (-22 to +104 °F) (T6)		
	Remote Sensor	-	-	-40 to +120 °C (-40 to +248 °F)
Linearity		±0.5% F.S.		
Hysteresis		±0.5% F.S.		
Sensitivity		±0.2% F.S.		
Repeatability		±0.3% F.S.		
Air Consumption	Fail-freeze	0.01 LPM (sup = 0.14 MPa) 0 CFM (sup = 20 psi)		
	Fail-safe	0.06 LPM (sup = 0.14 MPa) 0.002 CFM (sup = 20 psi)		
Flow Capacity	Fail-freeze	60 LPM (sup = 0.14 MPa) 2.12 CFM (sup = 20 psi)		
	Fail-safe	40 LPM (sup = 0.14 MPa) 1.41 CFM (sup = 20 psi)		
Output Characteristics		Linear, EQ%, Quick Open, User Set (5 or 18 Points)		
Material		Aluminium Diecasting	Stainless Steel 316	Aluminium Diecasting
Ingress Protection		IP66		
Explosion Protection Type		ATEX / IECEx Ex ia IIC T5/T6 Gb Ex ia IIIC T100°C/T85°C IP6X CCC Ex ia IIC T5/T6 Gb Ex iaD 21 T100°C/T85°C KCs Ex ia IIC T5/T6 Ex iaD IIIC T100°C/T85°C NEPSI (YT-2500 only) Ex ia IIC T5/T6 Gb Ex iaD 21 T100°C/T85°C EAC (YT-2500 only) 1Ex ia IIC T5...T6 Gb X Ex ia IIIC T100°C...T85°C Db X IP66		
Communication (Option)		HART (ver.5)		
L/S Rating	Mechanical Type (Omron)	AC 125 V, 3 A DC 30 V, 2 A	-	-
	Proximity Type (P&F)	DC 8.2 V 8.2 mA	-	-
Weight	Body	1.5 kg (3.3 lb)	2.9 kg (6.4 lb)	1.6 kg (3.4 lb)
	Linear Remote sensor	-	-	0.6 kg (1.3 lb)
	Rotary Remote sensor	-	-	1.0 kg (2.1 lb)

Product Code

YT-2501 - L - S - N - 2 - 4 - 2 - 3 - S - (1)

Model

YT-2500 = Aluminium housing
 YT-2550 = Stainless steel house
 YT-2501 = Aluminium housing with remote sensor

Motion Type

L = Linear
 R = Rotary

Acting Type

S = Single
 D = Double

Explosion Protection

Check certification restrictions.
 N = Non-Explosionproof
 i = ATEX, IECEx, KCs, NEPSI (YT-2500 only)
 E = EAC (YT-2500 only)
 Z = CCC

Lever Type

Linear	Rotary
1 = 10 to 40 mm	1 = M6 x 34L (N/A for YT-2501)
2 = 20 to 70 mm	2 = M6 x 63L (N/A for YT-2501)
3 = 50 to 100 mm	3 = M8 x 34L (N/A for YT-2501)
4 = 100 to 150 mm	4 = M8 x 63L (N/A for YT-2501)
	5 = NAMUR

Conduit & Air Connection

1 = G 1/2 - Rc 1/4 (N/A for YT-2550)
 2 = G 1/2 - 1/4 NPT
 3 = G 1/2 - G 1/4 (N/A for YT-2550)
 4 = M20 - 1/4 NPT (N/A for YT-2550)
 5 = 1/2 NPT - 1/4 NPT (N/A for YT-2550)

Communications

0 = None
 2 = HART protocol communication

Output Options

0 = None
 1 = 4-20 mA feedback
 2 = Limit switch - Mechanical Type (YT-2500 and YT-2550R only)
 3 = Limit switch - Proximity Type (YT-2500 and YT-2550R only)¹
 4 = 4-20 mA feedback + Limit switch - Mechanical Type (YT-2500 and YT-2550R only)
 5 = 4-20 mA feedback + Limit switch - Proximity Type¹ (YT-2500 and YT-2550R only)¹

Fail Option

F = Fail-freeze
 S = Fail-safe

Cable Length (YT-2501 only)

Standard cable length is 5 m.
 1 = 5 m
 2 = 10 m
 3 = 15 m
 4 = 20 m

Notes:

1. Inductive proximity limit switch internal type: -25 to +80 °C (-13 to 176 °F).

Smart Positioner YT-2600

Piezo technology with communications

Design features

- **Fail-freeze and fail-safe functions.** Enables the valve maintain the last position (fail-freeze) or move to a pre-determined position (fail-safe) on the loss of electrical power supply or the pneumatic supply air.
- **Explosionproof / flameproof housing.** Global certification for Zone 1 and Division 1 installations
- **Auto calibration.** Simple menu structure with options to auto calibrate all parameters or zero and end points only.
- **LCD display.** Alphanumeric digital display for process values and calibration.
- **Low air consumption level.** Almost zero air leakage.
- **Feedback signal.** Analogue feedback signals with 4-20 mA, transistor switch options.
- **PD control.** Pre-calibrated and user-configurable variables via front panel pushbutton menu.
- **HART® communication.** Allows commands, position feedback and diagnostics to be sent digitally over the current loop.
- **Front panel pushbuttons for configuration.** Four robust and positive acting pushbuttons for field configuration.



YT-2600 Aluminium Ex d Positioner

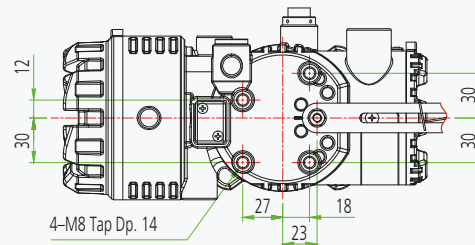
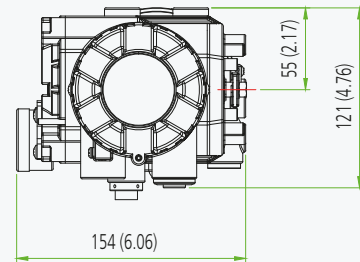
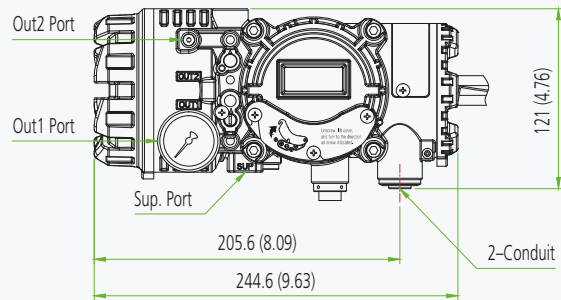

Dimensions: mm (Inches ")

Smart Positioner YT-2600

Item Type	YT-2600	
Input Signal	4-20 mA DC	
Supply Pressure	0.14 to 0.7 MPa = 1.4 to 7 bar = 20 to 102 psi	
Stroke	Linear Type	10 to 150 mm (0.4 to 6")
	Rotary Type	55 to 110°
Impedance	Max. 450 Ω @ 20 mA DC	
Air Connection	Rc ¼, ¼ NPT, G ¼	
Gauge Connection	Rc ⅛, ⅛ NPT	
Conduit	G ½, ½ NPT, M20x1.5P	
Operating Temp.	Standard Type	-30 to +80 °C (-22 to +176 °F)
	Explosion Temp.	-30 to +80 °C (-22 to +176 °F) (T5) -30 to +70 °C (-22 to +158 °F) (T6)
Linearity	±0.5% F.S.	
Hysteresis	±0.5% F.S.	
Sensitivity	±0.2% F.S.	
Repeatability	±0.3% F.S.	
Air Consumption	Fail-freeze	0.06 LPM (sup = 0.14 MPa) 0.002 CFM (sup = 20 psi)
	Fail-safe	0.06 LPM (sup = 0.14 MPa) 0.002 CFM (sup = 20 psi)
Flow Capacity	Fail-freeze	50 LPM (sup = 0.14 MPa) 1.77 CFM (sup = 20 psi)
	Fail-safe	40 LPM (sup = 0.14 MPa) 1.41 CFM (sup = 20 psi)
Output Characteristics	Linear, EQ%, Quick Open, User Set (5 or 18 Points)	
Material	Aluminium Diecasting	
Ingress Protection	IP66	
Explosion Protection Type	ATEX, IECEx, KCs Ex db IIC T5/T6 Ex tb IIC T100°C/T85°C	
	CCC Ex d IIC T5/T6 Gb Ex tD A21 IP66 T85°C / T100°C	
	EAC 1Ex d IIC T6...T5 Gb X Ex tb IIIC T85°C...T100°C Db X IP66	
Communication (Option)	HART (ver.5)	
Weight	3.0 kg (6.61 lb)	

Product Code

YT-2600 - L - S - C - 2 - 4 - 2 - 3 - S

Model

YT-2600 = Aluminium housing

Motion Type

L = Linear
R = Rotary

Acting Type

S = Single
D = Double

Explosion Protection

C = ATEX, IECEx, KCs E = EAC
Z = CCC

Lever Type

Linear	Rotary
1 = 10 to 40 mm	1 = M6 x 34L
2 = 20 to 70 mm	2 = M6 x 63L
3 = 50 to 100 mm	3 = M8 x 34L
4 = 100 to 150 mm	4 = M8 x 63L
	5 = NAMUR

Conduit & Air Connection

1 = G ½ - Rc ¼ (N/A for CCC)
2 = G ½ - ¼ NPT (N/A for CCC)
3 = G ½ - G ¼ (N/A for CCC)
4 = M20x1.5P - ¼ NPT
5 = ½ NPT - ¼ NPT

Communications

0 = None
2 = HART protocol communication

Output Options

0 = None
1 = 4 to 20 mA feedback
2 = Limit switch¹
3 = 4 to 20 mA feedback + Limit switch¹

Fail Option

F = Fail-freeze
S = Fail-safe

Notes:

1. Limit switch: DC 24 V (50 mA) and transistor type.

IP Converters YT-930 / YT-940

Design features

- **Flameproof housing (YT-940)** for Zone 1 installation.
- **High accuracy and sensitivity** with pressure sensor.
- **Analogue PID control.** High resolution proportional control
- **No effect from mounting orientation**

Item Type	YT-930	YT-940
Input Signal	4-20 mA DC	
Output Pressure	Standard	1 0.02 ~ 0.1 MPa (0.2 ~ 1.0 bar)
	Multi-range	2 0.00 ~ 0.12 MPa (0 ~ 1.2 bar)
		3 0.04 ~ 0.2 MPa (0.4 ~ 2.0 bar)
		4 0.00 ~ 0.23 MPa (0 ~ 2.3 bar)
Supply Pressure	Standard	1 0.13 ~ 0.16 MPa (1.3 ~ 1.6 bar)
	Multi-range	2 0.14 ~ 0.16 MPa (1.4 ~ 1.6 bar)
		3 0.22 ~ 0.24 MPa (2.2 ~ 2.4 bar)
		4 0.25 ~ 0.27 MPa (2.5 ~ 2.7 bar)
Explosion Protection Type	ATEX, IECEx Ex ia IIC T5/T6 Gb, Ex ia IIIC T100°C/ T85°C Db	FM, CSA Class I Division 1 Groups A,B,C,D Class II, III Division 1 Groups E,F,G Class I Zone 1 AEx d IIC T6 Ta=-40°C to +75°C, T5 Ta=-40°C to +85°C, Type 4X, IP66 Zone 21 AEx tb IIIC T85°C Ta= -40°C to +75°C, T100°C Ta= -40°C to +85°C, Type 4X, IP66 KCs Ex d IIC T5/T6
Air consumption	Below 2 LPM (sup = 0.14 MPa) Below 0.08 CFM (sup = 20 psi)	
Flow Capacity	70 LPM (sup = 0.14 MPa) 2.47 CFM (sup = 20 psi)	
Explosion Temp.	-40 to +60 °C (T5) / -40 to +40 °C (T6)	-40 to +85 °C (T5) / -40 to +75 °C (T6)
Operating Temp.	-40 to +85 °C (-22 to +185 °F)	
Linearity	±0.5% F.S.	
Hysteresis	±0.5% F.S.	
Sensitivity	±0.2% F.S.	
Repeatability	±0.3% F.S.	
Air Connection	Rc 1/4, 1/4 NPT	
Conduit	G 1/2	
Ingress Protection	IP66	Type 4X, IP66
Impedance	Max. 390Ω @20mA DC	Max. 313Ω @20mA DC
Material	Aluminium Diecasting	
Weight	1.6 kg (3.53 lb)	2.5 kg (5.6 lb)



YT-930

YT-940



Product Code

YT-930 - N - 1 - 1 - L - 0 - 0

Model

YT-930 = Intrinsically Safety Type
YT-940 = Flameproof Type

Explosion Protection

YT-930
N = Non-Explosionproof
i = ATEX, IECEx

YT-940
C = KCs, FM, CSA

Output Pressure

1 = 0.02 to 0.1 MPa
2 = 0.00 to 0.12 MPa
3 = 0.04 to 0.2 MPa
4 = 0.00 to 0.23 MPa

Conduit - Air Connection

1 = G 1/2 - Rc 1/4
2 = G 1/2 - 1/4 NPT

Operating Temp. (Non-explosionproof)¹

L = -40 to +85 °C (-40 to +185 °F)

Option

0 = None
1 = Feedback Signal (4-20 mA DC)

Gauge

0 = None
1² = 0 to 0.2 MPa
2² = 0 to 0.4 MPa

Notes:

1. This option is the normal operating temperature of the product and is not related to explosion protection temperature. See certificates for explosion protection temperature.
2. For 1 or 2 in Output Pressure option.
3. For 3 or 4 in Output Pressure option.

Dimensions: mm (Inches ")

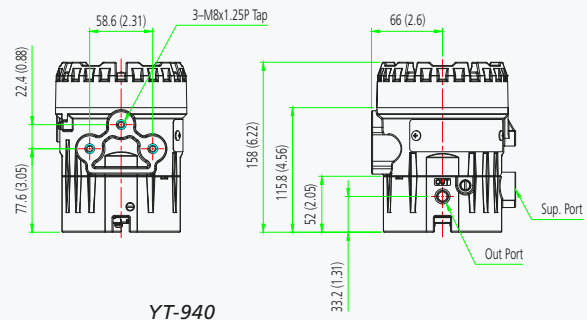
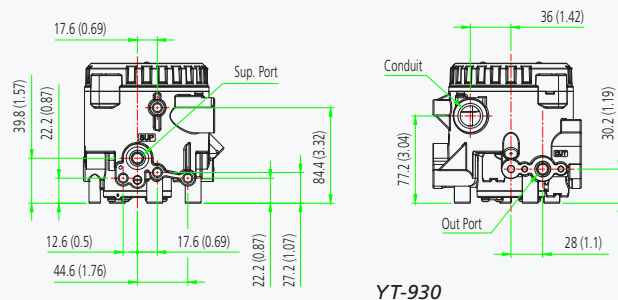

Air Filter Regulators YT-200 / YT-205 / YT-220 / YT-225

Design features

- **Stable output and repeatability.** Provides constant control under variable flow rates and supply pressures.
- **Relief flow capability.** Discharges pressure if outer pressure is higher than set pressure.
- **Light weight and compact size.** Reduces installation costs.
- **Five micron filter.** Protects pneumatic instruments from dirty air.
- **Manual or auto draining option**



YT-200 / YT-205 Flow (LPM)

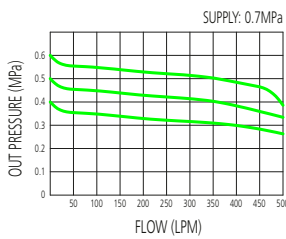

YT-220 / YT-225 Flow (LPM)

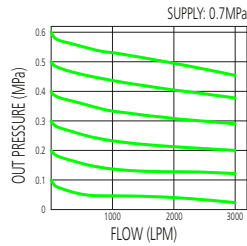

Product Code

YT-200 - A - N - 0 - 1 - 0

Model

YT-200 = Aluminium ¼"
 YT-205 = Stainless Steel ¼"
 YT-220 = Aluminium ½"
 YT-225 = Stainless Steel ½"

Adjustable Range

A = 0 to 0.42 MPa
 B = 0 to 0.84 MPa

Connection Type

P = Rc (N/A for YT-205 and YT-225)
 N = NPT

Gauge

0 = None
 1 = 0 to 0.4 MPa
 2 = 0 to 1.0 MPa

Operating Temp.

1 = -20 to +70 °C (-4 to +158 °F) (N/A for EAC)
 2 = -20 to +120 °C (-4 to +248 °F) (N/A for EAC)
 3 = -40 to +70 °C (-40 to +158 °F)
 4 = -50 to +70 °C (-58 to +158 °F) (EAC only)

Option

0 = Manual drain
 1 = Auto drain¹

Item Type	YT-200	YT-220	YT-205	YT-225
Max. Supply Pressure	1.7 MPa = 17 bar = 246.5 psi			
Max. Output Pressure	0.42 MPa (A Type), 0.84 MPa (B Type) 60.9 psi (A Type), 121.8 psi (B Type)			
Air Connection	Rc ¼, ¼ NPT	Rc ½, ½ NPT	¼ NPT	½ NPT
Gauge Connection	Rc ¼, ¼ NPT	Rc ¼, ¼ NPT	¼ NPT	¼ NPT
Operating Temp.	-20 to +70 °C (-4 to +158 °F) (Standard type)			
Min. Filtering Size	5 micron			
Material	Aluminium Diecasting		Stainless Steel 316	
Weight (Manual drain)	0.62 kg (1.4 lb)	0.88 kg (2 lb)	1.5 kg (3.3 lb)	2.2 kg (4.8 lb)

Notes:

1. Only "1" of Operating Temp. is available

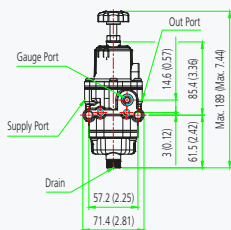

YT-200/205 Manual drain

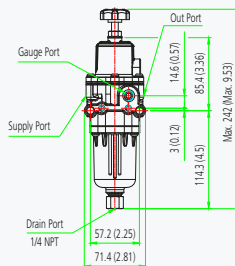

YT-200/205 Auto drain

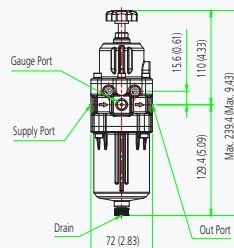

YT-220/225 Manual drain

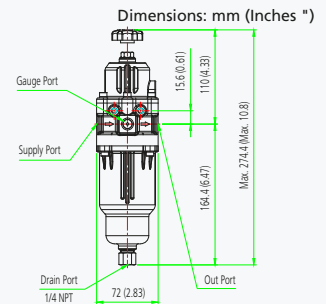

YT-220/225 Auto drain

Volume Boosters YT-300 / YT-305 / YT-320 / YT-325 / YT-310 / YT-315

Design features

- **Large flow capacity.** Specifically designed to be used in conjunction with valve positioners.
- **Optimal sensitivity.** Reacts to sudden change in supply pressure.
- **Fixed deadband.** Provides accurate and stable final positioning of the valve.
- **Internal bypass control.** Improves system stability.



YT-300

YT-325

YT-315



Item Type		YT-300 YT-305	YT-320 YT-325	YT-310 YT-315
Max. Supply Pressure		1 MPa = 10 bar = 145 psi		
Max. Signal / Output Pressure		0.7 MPa = 7 bar = 102 psi		
Signal/Output Pressure Ratio		1:1		
Flow Capacity (Cv)	Exhaust	1.32	2.08	5.24
	Output	1.19	2.72	4.91
Supply/Output Connection		Rc ¼, ¼ NPT	Rc ½, ½ NPT	¾ NPT
Signal Connection		Rc ¼, ¼ NPT		¼ NPT
Linearity		±1% F.S.		
Operating Temp.		-20 to +70 °C (-4 to +158 °F) (Standard type)		
Material	YT-300, YT-320, YT-310	Aluminium Diecasting		
	YT-305, YT-325, YT-315	Stainless Steel 316		
Weight	YT-300 YT-320 YT-310	0.5 kg (1.1 lb)	0.76 kg (1.7 lb)	2.3 kg (5.1 lb)
	YT-305 YT-325 YT-315	1.3 kg (2.9 lb)	1.9 kg (4.2 lb)	5 kg (11 lb)

Product Code

YT-300 - N - 1

Model

YT-300 = Aluminium ¼"
 YT-305 = Stainless Steel ¼"
 YT-320 = Aluminium ½"
 YT-325 = Stainless Steel ½"
 YT-310 = Aluminium ¾"
 YT-315 = Stainless Steel ¾"

Connection Type

P = Rc
 N = NPT

Operating Temp.

1 = -20 to +70 °C (-4 to +158 °F) (N/A for EAC)
 2 = -20 to +120 °C (-4 to +248 °F) (N/A for EAC)
 3 = -40 to +70 °C (-40 to +158 °F)
 4 = -60 to +70 °C (-76 to +158 °F) (EAC only)

Dimensions: mm (Inches ")

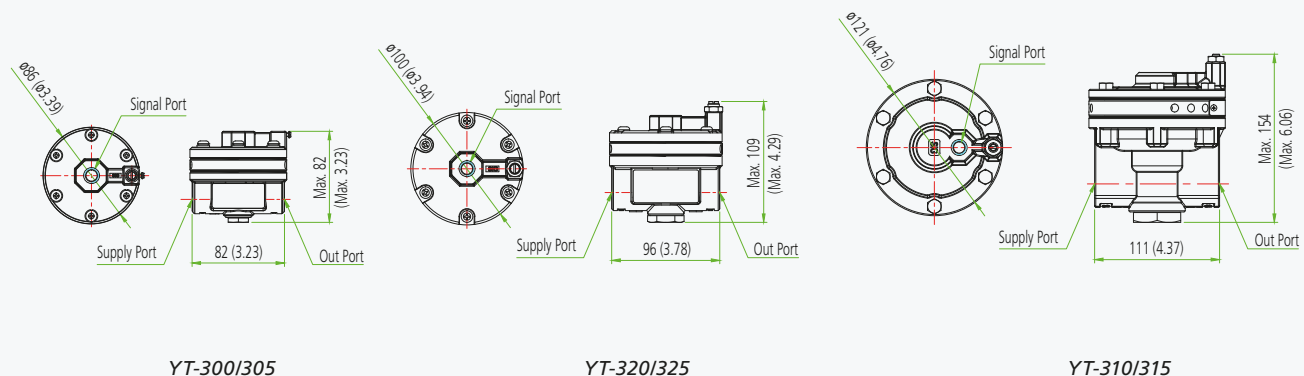

Lock-up Valves YT-400 / YT-405 / YT-430 / YT-435

Design features

- **Compact size.** No bracket is required.
- **Optimal sensitivity.** Detects small variation of the pressure - below 0.01 MPa.

Symbol

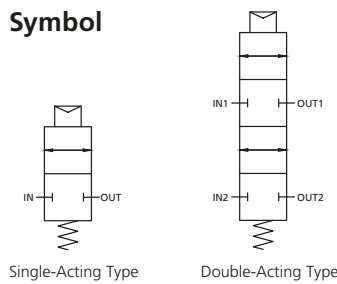

Single-Acting Type

Double-Acting Type



YT-400S

YT-405D

YT-430S

YT-435D



Item Type	YT-400	YT-405	YT-430	YT-435
Signal Pressure	0.14 to 0.7 MPa = 1.4 to 7 bar = 20 to 102 psi			
Max. Supply Pressure	Max. 1 MPa = 10 bar = 145 psi			
Signal Pressure Setting Range	Max. 0.7 MPa = 7 bar = 102 psi			
Hysteresis	Below 0.01 MPa = 0.1 bar = 1.45 psi			
Operating Temp.	-20 to +70 °C (-4 to +158 °F) (Standard type)			
Flow Capacity (Cv)	0.9		1.8	
Air Connection	Rc ¼", ¼ NPT	¼ NPT	¾ NPT	
Signal Connection	Rc ¼", ¼ NPT	¼ NPT	¼ NPT	
Material	Aluminium Diecasting	Stainless Steel 316	Aluminium Diecasting	Stainless Steel 316
Weight	Single	0.47 kg (1.1 lb)	1.3 kg (2.2 lb)	3.3 kg (7.3 lb)
	Double	0.66 kg (1.5 lb)	1.5 kg (3.3 lb)	2.7 kg (6 lb)

Product Code

YT-400 - S - P - 1

Model

YT-400 = Aluminium ¼"
YT-405 = Stainless Steel ¼"
YT-430 = Aluminium ¾"
YT-435 = Stainless Steel ¾"

Acting Type

S = Single
D = Double

Connection Type (YT-405/430/435 are only available in NPT connection)

P = Rc
N = NPT

Operating Temp.

1 = -20 to +70 °C (-4 to +158 °F) (N/A for EAC)
2 = -20 to +120 °C (-4 to +248 °F) (N/A for EAC)
3 = -40 to +70 °C (-40 to +158 °F)
4 = -50 to +70 °C (-58 to +158 °F) (EAC only)

Dimensions: mm (Inches ")

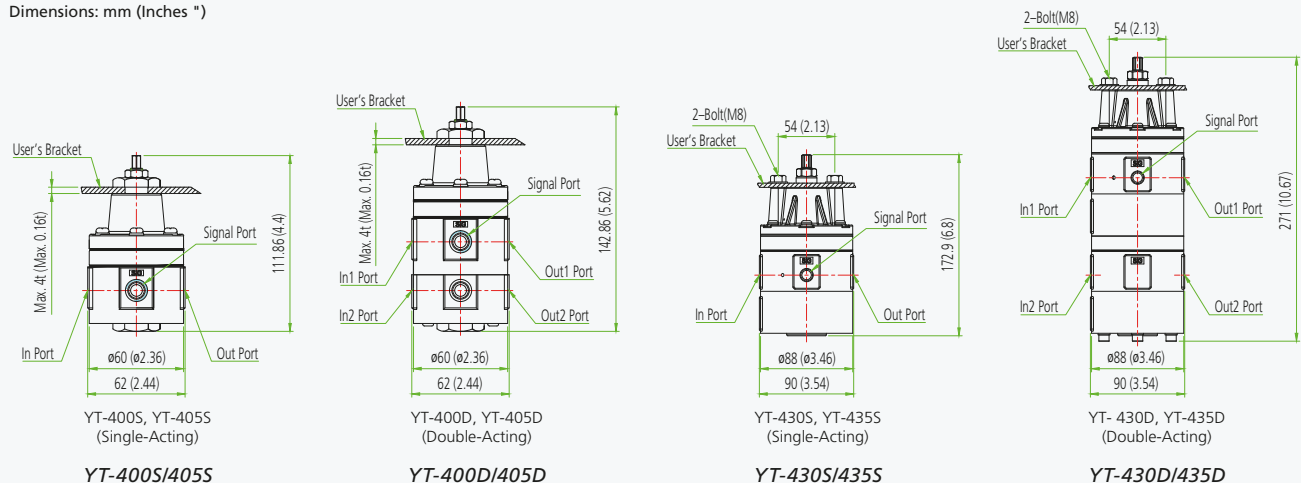

YT-400S, YT-405S
(Single-Acting)
YT-400S/405S

YT-400D, YT-405D
(Double-Acting)
YT-400D/405D

YT-430S, YT-435S
(Single-Acting)
YT-430S/435S

YT-430D, YT-435D
(Double-Acting)
YT-430D/435D

Snap Acting Relays YT-520 / YT-525 / YT-530 / YT-535

Design features

- **Rugged and reliable design.** Suitable for all environments.
- **Designed for valve actuation.** Changes the direction of the supply air to a 'fail-safe' circuit, or fail-freeze in its last known position, on sudden loss of supply air pressure.



YT-520S

YT-525D

YT-530D

YT-535S



Symbol

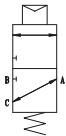

Single-Acting Type

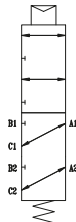

Double-Acting Type

Item Type	YT-520	YT-525	YT-530	YT-535
Hysteresis	= Below 0.01 MPa = 0.1 bar = 1.45 psi			
Signal Pressure	0.14 to 0.7 MPa = 1.4 to 7 bar = 20 to 102 psi			
Max. Supply Pressure	1 MPa = 10 bar = 145 psi			
Operating Temp.	-20 to +70 °C (-4 to +158 °F) (Standard type)			
Signal Connection	¼ NPT			
A, B, C Connection	¼ NPT		⅜ NPT	
Flow Capacity (Cv)	0.9		1.8	
Material	Aluminium Diecasting	Stainless Steel 316	Aluminium Diecasting	Stainless Steel 316
Weight	Single	0.71 kg (1.6 lb)	1.7 kg (3.8 lb)	3.3 kg (7.3 lb)
	Double	1.3 kg (2.9 lb)	3.1 kg (6.9 lb)	2.7kg (6 lb)

Product Code

YT-520 - S - 2 - 1

Model

YT-520 = Aluminium ¼"
 YT-525 = Stainless Steel ¼"
 YT-530 = Aluminium ⅜"
 YT-535 = Stainless Steel ⅜"

Acting Type

S = Single
 D = Double

Connection Type

2 = NPT

Operating Temp.

1 = -20 to +70 °C (-4 to +158 °F) (N/A for EAC)
 2 = -20 to +120 °C (-4 to +248 °F) (N/A for EAC)
 3 = -40 to +70 °C (-40 to +158 °F)
 4 = -50 to +70 °C (-58 to +158 °F) (EAC only)

Dimensions: mm (Inches ")

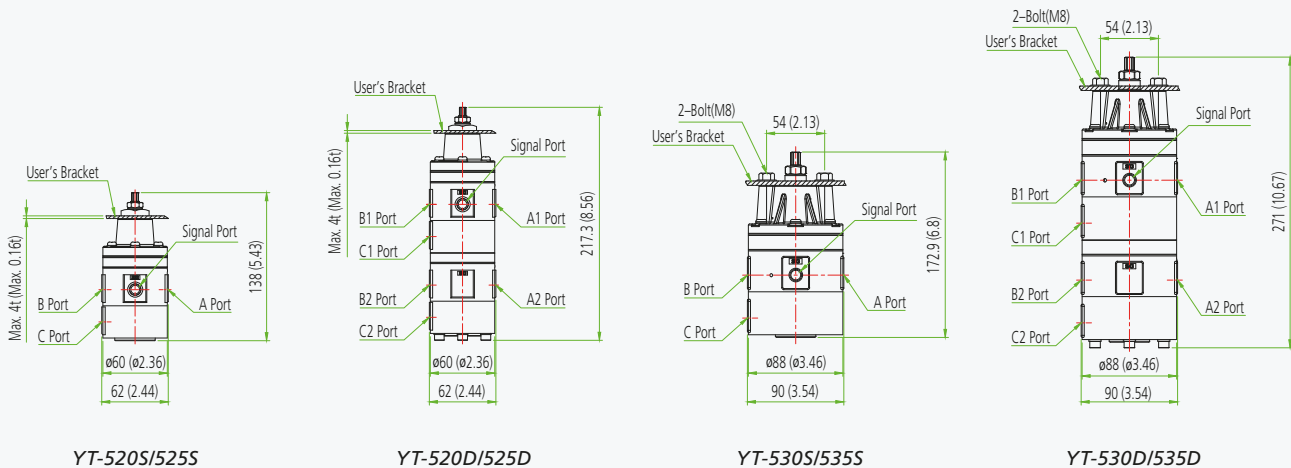

Solenoid Valve YT-720

Design features

- **Balance spool type.** No require of backing spring.
- **AC and DC Power options.** Interchangeable AC and DC coils.
- **Manual override options.** For maintenance or emergency operation.
- **Rotational connection.** Coil assembly can be rotated.

Symbol

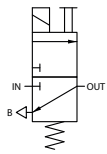

YT-720S (3-Way)

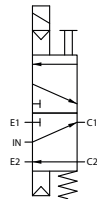

YT-720D (5-Way)



YT-720S (3-Way)



YT-720D (5-Way)



Item Type	YT-720S	YT-720D
Max. Supply Pressure	0 to 0.4 MPa 0 to 0.7 MPa	0.1 to 1 MPa
Flow Capacity (Cv)	Output	0.2 (Φ3) at 0.4 MPa 0.084 (Φ1.6) at 0.7 MPa
	Exhaust	0.093
Rating Current	AC 220 V	60 mA (11 W)
	AC 110 V	130 mA (12 W)
	DC 24 V	580 mA (14 W)
Frequency	50 to 60 Hz	
Explosion Protection Type	KCs Ex d IIC T6	
Connection Type	Rc 1/4, 1/4 NPT	
Conduit	G 1/2	
Coil Insulation Grade	Class F	
Operating Temp.	Operating	-20 to +70 °C (-4 to +158 °F)
	Explosion	-20 to +50 °C (-4 to +122 °F)
Weight	0.86 kg (1.9 lb)	1.3 kg (2.8 lb)

Product Code

YT-720-S-P-1-1

Model
YT-720

Valve Type
S = 3-Way
D = 5-Way

Connection Type
P = Rc
N = NPT

Power Source
1 = AC 110 V
2 = AC 220 V
3 = DC 24 V

Pressure
1 = 0 to 0.4 MPa (3-Way)
2 = 0 to 0.7 MPa (3-Way)
3 = 0.1 to 1.0 MPa (5-Way)

Dimensions: mm (Inches ")

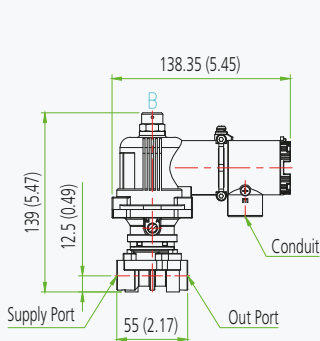

YT-720S (3-Way)

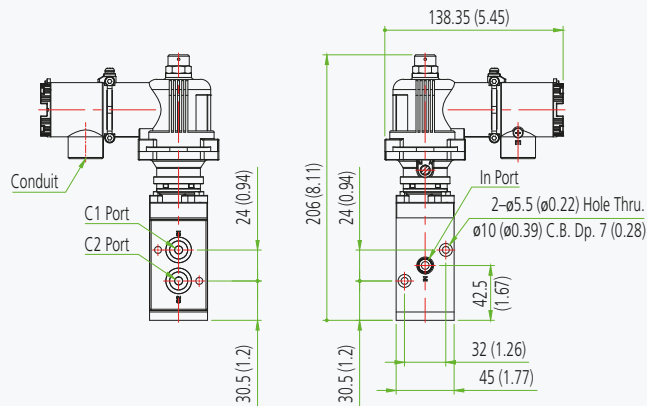

YT-720D (5-Way)

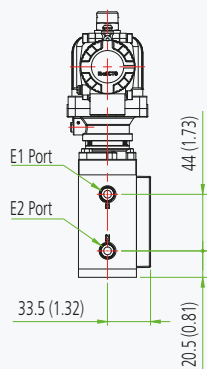

Position Transmitter SPTM-5V

Design features

- **Convenient wiring: two wire type.**
- **High accuracy and reliability.** Stable output and repeatability.
- **Simple change for RA v.s. DA action setting.**
- **Smart setting.** Easy setting of zero and span by pressing the buttons (two or five points setup).



SPTM-5V



Item Type	SPTM-5VL	SPTM-5VR
Input Type	2 Wire	
Input Stroke	10 to 150 mm	55 to 100 °
Output Signal	4-20 mA DC	
Load Resistance	$R_L \leq \frac{V_s[V] - 9[V]}{I [mA]}$	
Supply Voltage	9 to 28 VDC	
Conduit	G 1/2	
Operating Temp.	-40 to +85 °C (-40 to +185 °F)	
Linearity	±1% F.S.	
Hysteresis	±0.2% F.S.	
Sensitivity	±0.2% F.S.	
Explosion Protection Type	EAC 1Ex ia IIC T5 Gb NEPSI Ex ia IIC T5 Gb	
Ingress Protection	IP67	
Material	Aluminium Diecasting	
Weight	0.6 kg (1.3 lb)	

Product Code

SPTM-5V - L - I - 1 - 0

Model
SPTM-5V

Motion Type
L = Linear
R = Rotary

Explosion Protection
N = Non-explosion
Z = NEPSI
E = EAC

Lever Type
Linear
1 = 10 to 40 mm
2 = 20 to 70 mm
3 = 50 to 100 mm
4 = 100 to 150 mm
Rotary
1 = Standard Lever
2 = NAMUR

Option
0 = None
1 = With LCD

Dimensions: mm (Inches ")

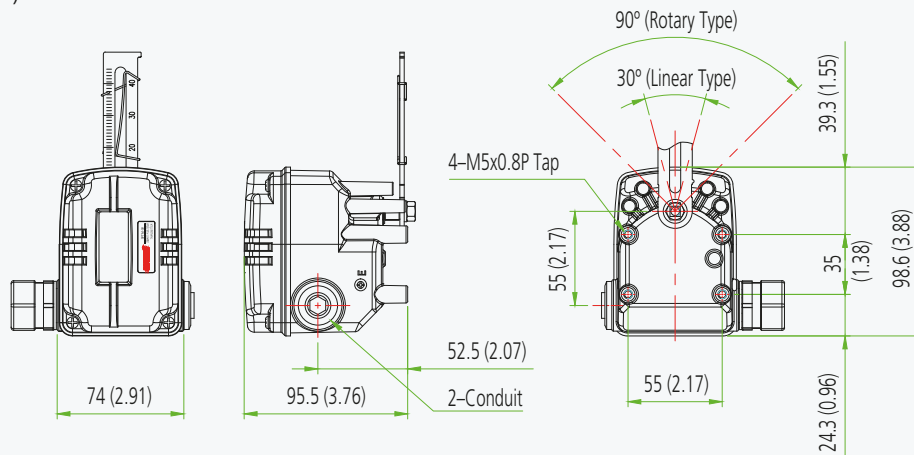

Position Transmitters SPTM-6V / SPTM-65V

Design features

- **Loop powered two wire type.**
- **High accuracy and reliability.** Stable output and repeatability.
- **Reverse or direct acting.** Easy to configure options.
- **Smart setting.** Easy setting of zero and span by pressing the buttons (two or five points setup).



SPTM-6V



SPTM-65V



Item Type	SPTM-6V	SPTM-65V
Connection Type	2 Wire	
Input Stroke	Linear	10 to 150 mm
	Rotary	55 to 100 °
Output Signal	4-20 mA DC	
Load Resistance	$R_L \leq \frac{V_s[v] - 9[v]}{I [mA]}$	
Supply Voltage	9 to 28 VDC	
Conduit	G 1/2 or 1/2 NPT only for NEPSI	
Operating Temp.	Operating	-40 to +85 °C (-40 to +185 °F)
	Explosion	KCs, NEPSI: -40 to 60 °C, EAC: -60 to 60 °C
Linearity	±1% F.S.	
Hysteresis	±0.2% F.S.	
Sensitivity	±0.2% F.S.	
Explosion Protection Type	EAC 1Ex d IIC T6 Gb KCs Ex d NEPSI Ex d IIC T6 Gb	
Ingress Protection	IP67	
Material	Aluminium Diecasting	Stainless Steel 316
Weight	1.3 kg (2.9 lb)	2.8 kg (6.17 lb)

Product Code

SPTM-6V - L - C - 1

Model

SPTM-6V = Flameproof Aluminium
 SPTM-65V = Flameproof Stainless Steel

Motion Type

L = Linear
 R = Rotary

Explosion Protection

E = EAC
 Z = NEPSI
 C = KCs

Lever Type

Linear
 1 = 10 to 40 mm
 2 = 20 to 70 mm
 3 = 50 to 100 mm
 4 = 100 to 150 mm
 Rotary
 1 = Standard Lever
 2 = NAMUR

Dimensions: mm (Inches ")

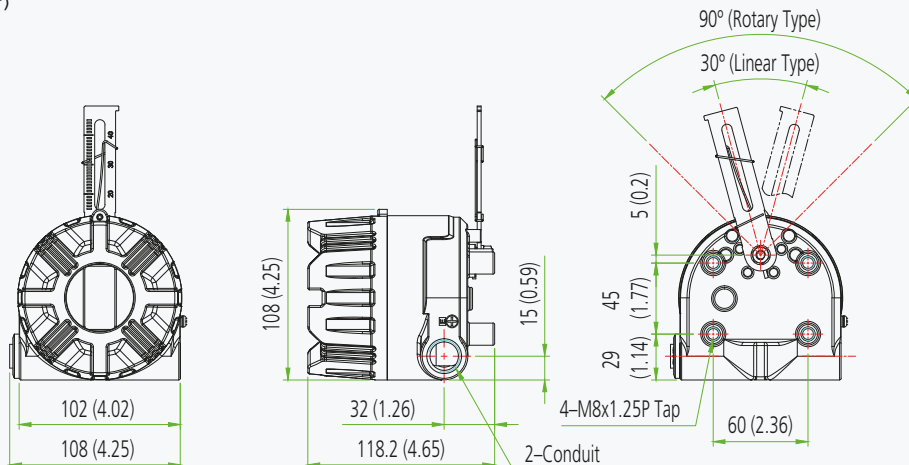

Limit Switch Box YT-850

Design features

- **Visual position indicator.** 360° viewing angle.
- **Multiple output signals.** Eight contacts of terminal ports.
- **Universal compatibility.** Suitable for any rotary motion actuator <ISO5211>.
- **Easy configuration.** Simple adjustment of cam position.
- **Dual conduit entries.** Separate connections for power and signal cables.



YT-850



Item Type	YT-850M	YT-850P
Switch Type	Mechanical Switch (2xSPDT) 5S5GL (Omron)	Inductive Proximity Sensor PSN17-5DNU (Autonics, NPN type)
Switch Rating	AC 250 V 3 A 125 V 5 A	-
	DC 250 V 0.2 A, 125 V 0.4 A, 30 V 4 A, 14 V 5 A, 8 V 5 A	12 - 24 VDC
Ingress Protection	IP67	
Operating Temp.	-25 to +70 °C (-13 to +158 °F)	
Conduit Entry	½ NPT, G ½, M20x1.5P	
Terminal	8 Points	
Mounting Bracket	NAMUR VDI / VDE 3845, ISO 5211	
Material	Aluminium Diecasting	
Weight	880 g (1.94 lb)	

Product Code

YT-850 - M - 1 - 0

Model

YT-850 = Weatherproof Aluminium

Switching Type

M = Mechanical Switch
P = Inductive Proximity Type

Conduit

1 = ½ NPT
3 = G ½
4 = M20x1.5P

Bracket Type

0 = None
1 = ST-1 (30*80,H20)
2 = ST-2 (30*80,H30)
3 = ST-3 (30*130,H30)
4 = ST-4 (30*130,H50)

Dimensions: mm (Inches ")

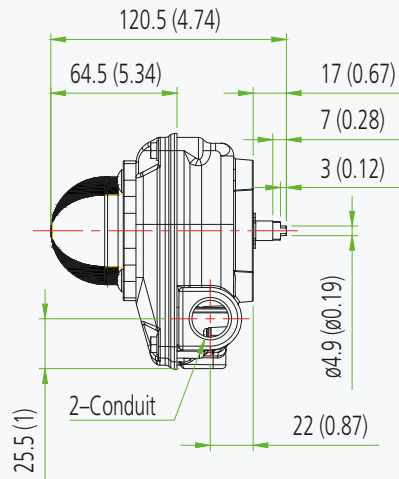
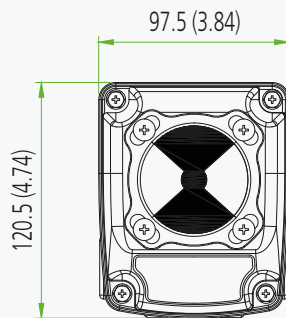

Limit Switch Boxes YT-870 / YT-875

Design features

- **Visual position indicator.** 360° viewing angle.
- **Multiple output signals.** Eight contacts of terminal ports.
- **Universal compatibility.** Suitable for rotary actuators (ISO 5211).
- **Easy configuration.** Simple adjustment of cam position.
- **Dual conduit entries.** Separate power & signal cable connections.



YT-870

YT-875



Item Type		YT-870M YT-875M	YT-870P YT-875P	YT-870D YT-875D
Switch Type		Mech. Switch (2 x SPDT)	Inductive Proximity Sensor	Mech. Switch (2 x DPDT)
		SS5GL (Omron)	PS17-5DNU (Autonics, NPN type)	DZ-10G-1B (Omron)
Switch Rating	AC	250 V 5 A 125 V 5 A	-	125 V or 250 V 10A
	DC	250 V 0.2 A, 125 V 0.4 A, 30 V 4 A, 14 V 5 A, 8 V 5 A	12 - 24 V	8.2 V
				125 V 0.5 A, 250 V 0.25 A, 30 V 10 A, 14 V 10 A, 8 V 10 A
Ingress Protection		Type 4, 4X, IP 67		
Explosion Protection Type		ATEX, IECEx Ex db IIC T6. Ex tb IIIC T85°C CSA Ex db IIC T6. Class I, Zone 1, AEx db IIC T6. Class II, Division 1, Groups E, F and G, Ex tb IIIC T85°C. Zone21, AEx tb IIIC T85°C KCs Ex d IIC T6 CCC Ex d IIC T6 Gb. Ex tD A21 IP67 T85°C		
Operating Temp.		-20 to +60 °C (-4 to +140 °F)		
Conduit Entry		YT-870: ¾ NPT, G ¾, M20x1.5P, ½ NPT YT-875: ¾ NPT		
Terminal		YT-870D, 875D = 12 Points		
Mounting Bracket		NAMUR VDI / VDE 3845, ISO 5211		
Material and Weight		YT-870 Aluminium Diecasting: 1.5 kg (3.3 lb) YT-875 Stainless Steel 316: 3.5 kg (7.7 lb)		

Product Code

YT-870 - M - 1 - 0 - 0 -

Model

YT-870 = Flameproof Aluminium
YT-875 = Flameproof Stainless Steel

Switching Type

M = Mechanical Type (2 x SPDT)
P = Inductive Proximity Type¹
D = Mechanical Type (2 x DPDT)

Conduit

1 = ¾ NPT
2 = G ¾ (YT-870 only,
NA for CCC)
3 = M20x1.5P (YT-870 only)
4 = ½ NPT (YT-870 only)

Bracket Type

0 = None
1 = ST-1 (30*80,H20)
2 = ST-2 (30*80,H30)
3 = ST-3 (30*130,H30)
4 = ST-4 (30*130,H50)

Option

0 = None
1 = SPTM²

Explosion Protection

Blank = ATEX, IECEx, CSA, KCs
Z = CCC

Notes:

1. Standard type is PN17-5DNU (Autonics, NPN type), but PSN17-5DPU (Autonics, PNP) and NJ2-V3-N (P&F, NC type) are also available. 2. Only M of Switching type is available.

Dimensions: mm (Inches ")

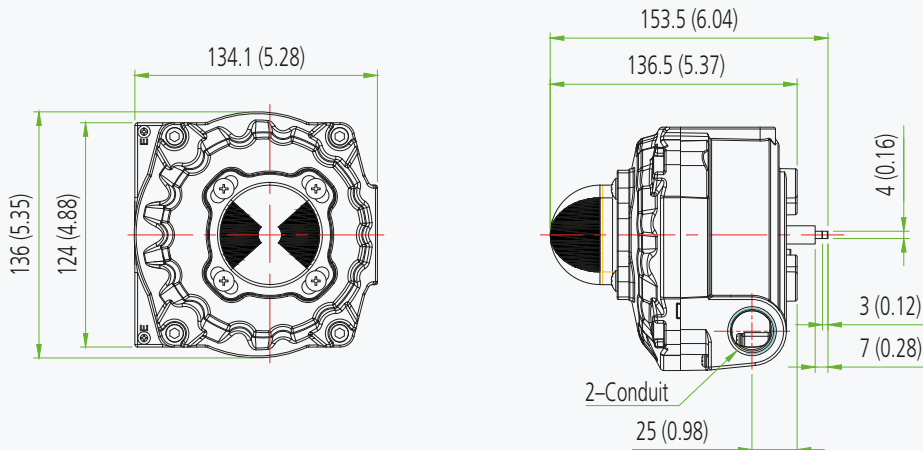

Examples for Installation (Linear Type)

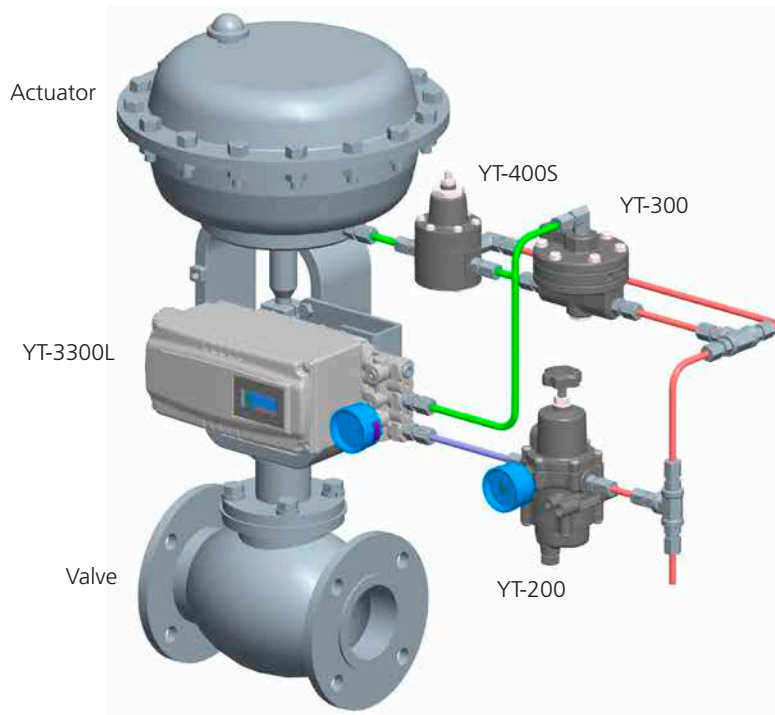

YT-3300L (Single-Acting) Application Example

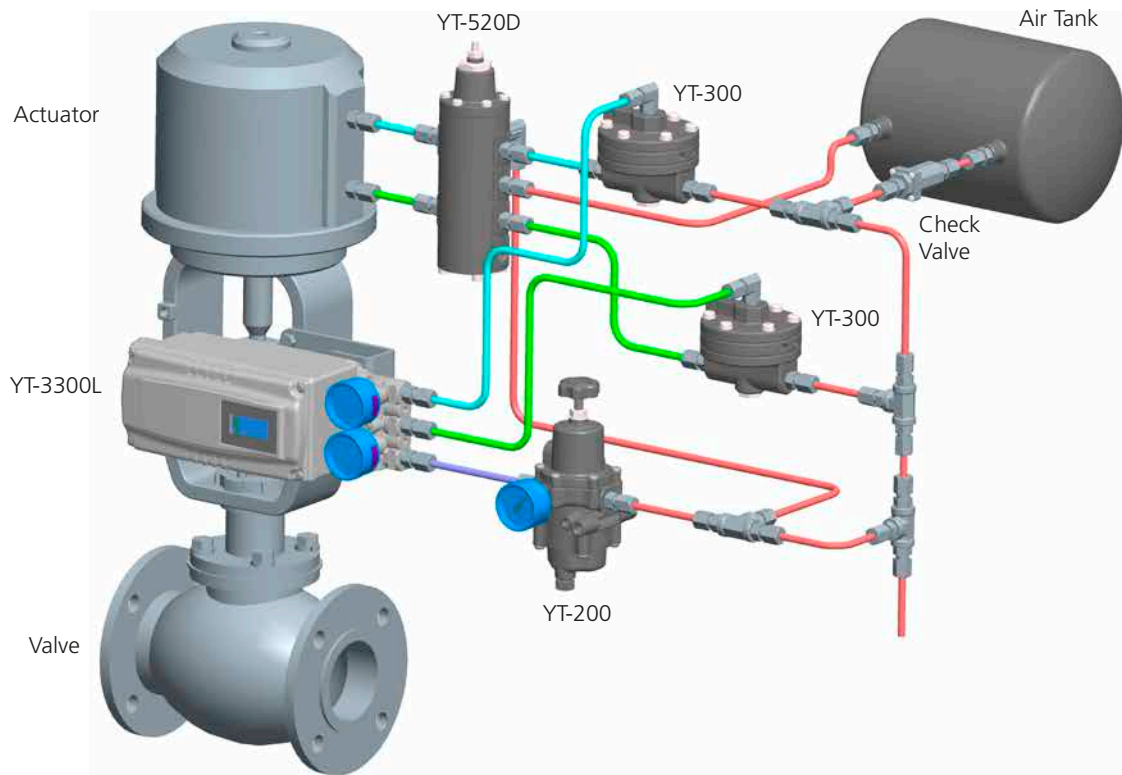

YT-3300L (Double-Acting) Application Example

Examples for Installation (Rotary Type)

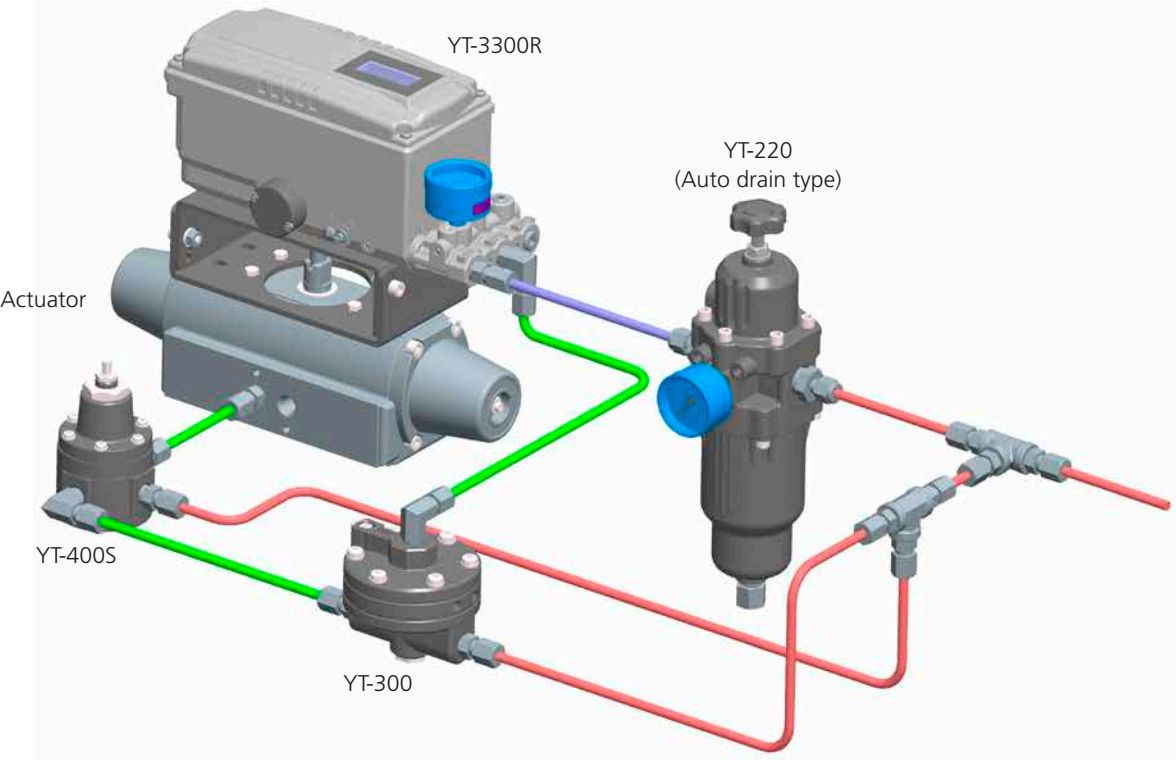

YT-3300R (Single-Acting) Application Example

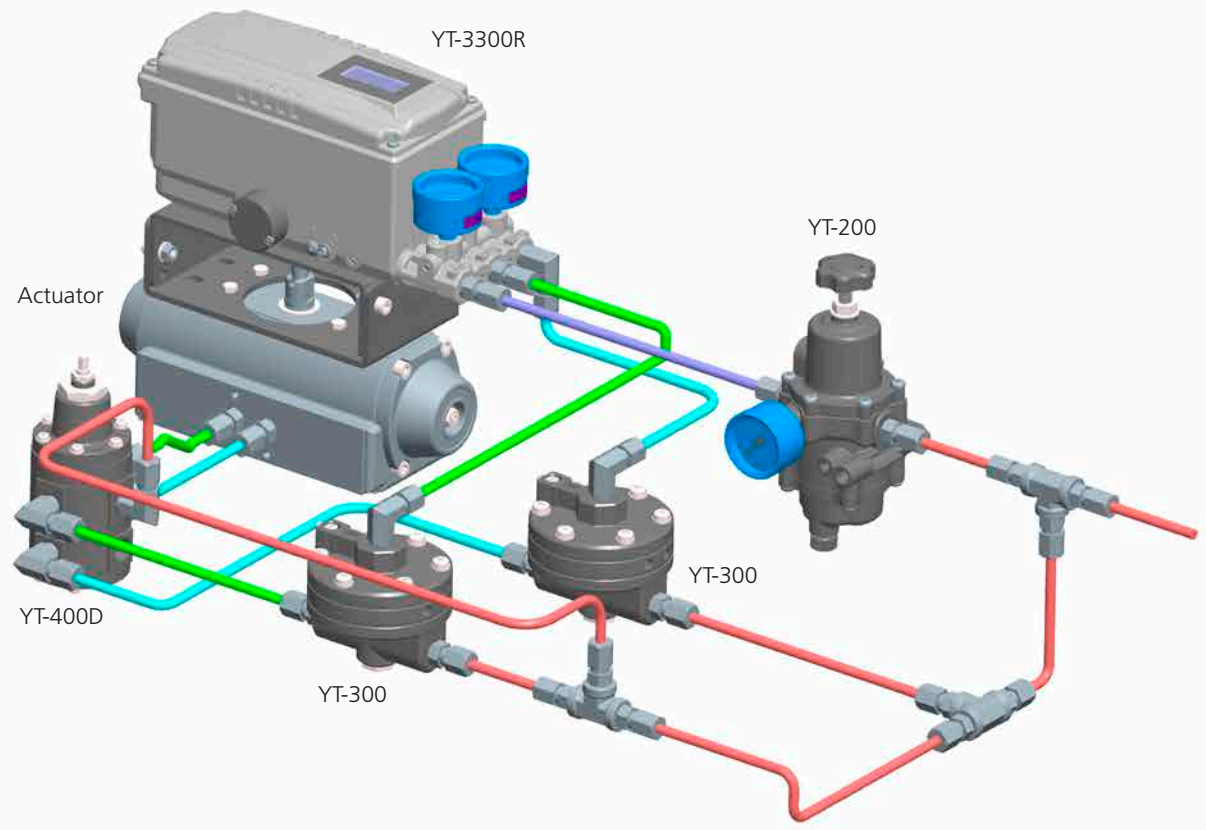

YT-3300R (Double-Acting) Application Example

Brackets and Levers

YT-850 & 870 & 875 Bracket Series

Bracket Type	H1	H2	L1	L2
ST-1	20	30.5	80	100
ST-2	30	40.5		
ST-3	30	40.5		
ST-4	50	60.5	130	150

UNIT: mm

Lever Series

Lever Type	Stroke	L1	L2
1	10 - 40	121.2	68.2
2	30 - 70	195	120
3	60 - 100	277	122
4	100 - 150	400	

Type 1, 2, 3

SPTM-5V Rotary Standard Lever Type

Type 4

YT-1000 & 1200 Linear Type

SPTM-6V & SPTM-65V Rotary Standard Lever Type

Lever Type	Stroke	L1	L2
1	10 - 40	93	67
2	20 - 70	153.5	106.5
3	50 - 100	214	117
4	100 - 150	307.3	

Type 1, 2, 3

Lever Type	L1	L2	M
1	34	9	M
2	63	37	M6
3	34	9	M8
4	63	37	

Rotary Fork Lever Type

Type 4

YT-2500 & 2550 & 2600 & 3303 & 3400 & 3450 & SPTM-5V & SPTM-6V & SPTM-65V Linear Type

Model	L1	L2
EP & PIP Positioner	7	11
Smart Positioner & SPTM-6V & SPTM-65V	4	8
SPTM-5V	4	9
YT-850 & 870 & 875	3	7

Rotary Namur Lever Type

Stroke	L1	L2	W	H
5 - 35	96.3	80.3	20	13

YT-2700 Linear Type

Type 0, 1, 2

Type 3, 4, 5, 6

YT-3300 & 3350 & 3700 & 3750 Linear Type

Lever Type	Stroke	L1	L2	L3
0 (Standard)	10 - 40	45	55	40.9
1 (Standard)	20 - 100	91	115	
2 (Standard)	90 - 50	85	165	
3 (Adapter)	16 - 30	27	43	
4 (Adapter)	16 - 60	64	80	
5 (Adapter)	16 - 100	96	113	
6 (Adapter)	90 - 150	80	167	

YT-3300
YT-3350
Only

Appendix A: Equipment Certification Requirements for Hazardous Locations

ATEX & IECEx

Typical ATEX & IECEx Marking [*ATEX only]

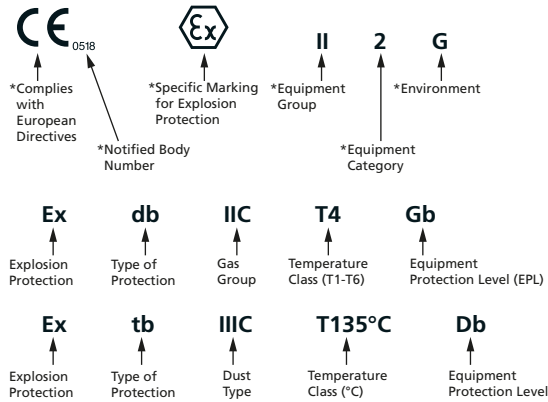

cCS Aus

Typical North American Marking (CSA)

Class I, Division 1, Groups A,B,C,D T4



Class II, Division 1, Groups E,F,G



Class I, Zone 0, AEx ia IIC T4



Protection Concepts

Type of Protection	Symbol	Typical IEC EPL	Typical Zone(s)	IEC Standard	Basic Concept of Protection
Electrical Equipment for Gases, Vapours and Mists (G)					
General Requirements	-	-	-	IEC 60079-0	-
Optical Radiation	Op pr Op sh Op is	Gb Ga Ga	1, 2 0, 1, 2 0, 1, 2	IEC 60079-28	Protection against ignitions from optical radiation
Increased Safety	eb ec	Gb Gc	1, 2 2	IEC 60079-7	No arcs, sparks or hot surfaces. Enclosure IP54 or better
Type 'n' (non-sparking)	nA	Gc	2	IEC 60079-15	-
Flameproof	da db dc	Ga Gb Gc	0, 1, 2 1, 2 2	IEC 60079-1	Contain the explosion, quench the flame
Type 'n' (enclosed break)	nC	Gc	2	IEC 60079-15	-
Quartz / Sand filled	q	Gb	1, 2	IEC 60079-5	Quench the flame
Intrinsic Safety	ia ib ic	Ga Gb Gc	0, 1, 2 1, 2 2	IEC 60079-11	Limit the energy of sparks and surface temperatures
Type 'n' (sealing & hermetic sealing)	nC	Gc	2	IEC 60079-15	-
Type 'n' (restricted breathing)	nR	Gc	2	IEC 60079-15	Keep the flammable gas out
Encapsulation	ma mb mc	Ga Gb Gc	0, 1, 2 1, 2 2	IEC 60079-18	-
Electrical Equipment for Combustible Dusts (D)					
General Requirements	-	-	-	IEC 60079-0	-
Optical Radiation	Op pr Op sh Op is	Db Da Da	21, 22 20, 21, 22 20, 21, 22	IEC 60079-28	Protection against ignitions from optical radiation
Enclosure	ta tb tc	Da Db Dc	20, 21, 22 21, 22 22	IEC 60079-31	Standard protection for dusts, rugged tight enclosure
Intrinsic Safety	ia ib ic	Da Db Dc	20, 21, 22 21, 22 22	IEC 60079-11	Limit the energy of sparks and surface temperatures
Encapsulation	ma mb mc	Da Db Dc	20, 21, 22 21, 22 22	IEC 60079-18	Protection by encapsulation of incandescent parts
Electrical Equipment for Combustible Dusts (D)					
General Requirements	-	-	-	EN 13463-1	-
General Requirements	h	Ga, Gb, Gc Da, Db, Dc	0, 1, 2 20, 21, 22	IEC 80079-36	Low potential energy
Flow Restricted Enclosure	fr	-	-	EN 13463-2	Relies on tight seals, closely matched joints and tough enclosures to restrict the breathing of the enclosure
Flameproof Enclosure	d	-	-	EN 13463-3	-
Constructional Safety	c	-	0, 1, 2 20, 21, 22	EN 13463-5	Ignition hazards eliminated by good engineering methods
Constructional Safety	h	Ga, Gb, Gc Da, Db, Dc	0, 1, 2 20, 21, 22	IEC 80079-37	-
Control of Ignition Source	b	-	-	EN 13463-6	Control equipment fitted to detect malfunctions
Control of Ignition Source	h	Ga, Gb, Gc Da, Db, Dc	0, 1, 2 20, 21, 22	IEC 80079-37	-

Protection Concepts

Type of Protection	Code	Country	Class	Division / Zone	Standard	Basic Concept of Protection
Electrical Equipment for Flammable Gas, Vapors and Mists - Class I						
General Requirements	AEx Ex	US CA	Class I Class I	Division 1 & 2 Zone 1 & 2	FM 3600 - ISA 60079-0 CSA 60079-0	-
Increased Safety	AEx e Ex e	US CA	Class I Class I	Zone 1	ISA 60079-7 CSA C22.2 No. 60079-7	-
Non-Incandive	(NI) (NI)	US CA	Class I Class I	Division 2 Division 2	ISA 12.12.01 / FM 3611 C22.2 No. 213	No arcs, sparks or hot surfaces
Non-Sparking	AEx nA Ex nA	US CA	Class I Class I	Zone 2 Zone 2	ISA 60079-15 CSA C22.2 No. 60079-15	-
Explosionproof	(XP) (XP)	US CA	Class I Class I	Division 1 Division 1	UL 1203 / FM 3615 C22.2 No. 30	Contain the explosion and extinguish the flame
Flameproof	AEx d AEx d Ex d	US CA	Class I Class I Class I	Zone 1 Zone 1 Zone 1	ISA 60079-1 UL 1203 / FM 3615 CSA 60079-1	-
Enclosed Break	AEx nC Ex nC	US CA	Class I Class I	Zone 2 Zone 2	ISA 60079-15 CSA C22.2 No. 60079-15	-
Intrinsic Safety	(IS) (IS) AEx ia AEx ib EX ia EX ib	US CA US US CA CA	Class I Class I Class I Class I Class I Class I	Division 1 Division 1 Zone 0 Zone 1 Zone 0 Zone 1	UL 913 / FM 3610 C22.2 No. 157 ISA 60079-11 / FM 3610 ISA 60079-11 / FM 3610 CSA C22.2 No. 60079-11 CSA C22.2 No. 60079-11	Limit energy of sparks and surface temperature
Limited Energy	AEx nC Ex nL	US CA	Class I Class I	Zone 2 Zone 2	ISA 60079-15 CSA C22.2 No. 60079-15	-
Restricted Breathing	AEx nR Ex nR	US CA	Class I Class I	Zone 2 Zone 2	ISA 60079-15 CSA C22.2 No. 60079-15	Keep flammable gas out
Encapsulated	AEx ma AEx m Ex m AEx mb	US CA US US	Class I Class I Class I Class I	Zone 0 Zone 1 Zone 1 Zone 1	ISA 60079-18 ISA 60079-18 CSA C22.2 No. 60079-18 ISA 60079-18	-
Electrical Equipment for Flammable Gas, Vapors and Mists - Class I						
General Requirements	Ex	US CA CA US	Class II Class II Class III Class III	Division 1 & 2 Division 1 & 2 Division 1 & 2 Zone 20, 21, 22	FM 3600 CSA C22.2 No.0 FM 3600 CSA C22.2 No.0 ISA 60079-0	-
Dust Ignition Proof	-	US CA	Class II Class II	Division 1 Division 1	UL 1203 / FM 3616 CSA C22.2 No. 25	-
Dust Protected	-	US CA	Class II Class II	Division 2 Division 2	ISA 12.12.01 / FM 3611 CSA C22.2 No. 25	-
Protection by Enclosure	AEx ta AEx tb AEx tc Ex ta Ex tb Ex tc	US US US CA CA CA	Class II Class II Class II Class II Class II Class II	Zone 20 Zone 21 Zone 22 Zone 20 Zone 21 Zone 22	ISA 60079-31 ISA 60079-31 ISA 60079-31 CSA C22.2 No. 60079-31 CSA C22.2 No. 60079-31 CSA C22.2 No. 60079-31	Keep combustible dust out
Encapsulation	AEx maD AEx mbD	US US	- -	Zone 20 Zone 21	ISA 60079-18 ISA 60079-18	-
Intrinsic Safety	(IS) (IS) AEx iaD AEx ibD (IS) (IS)	US CA US US US CA	Class II Class II Class II Class II Class III Class III	Division 1 Division 1 Zone 20 Zone 21 Division 1 Division 1	UL 913 / FM 3610 CSA C22.2 No. 157 ISA 60079-11 ISA 60079-11 UL 913 / FM 3610 CSA C22.2 No. 157	Limit energy of sparks and surface temperature

Appendix A: Equipment Certification Requirements for Hazardous Locations

ATEX & IECEx Certificate Number

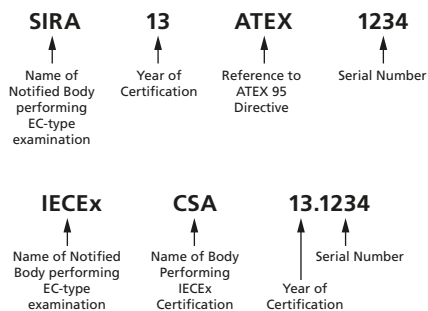

Suffixes: U – component certification
X – special conditions for safe use apply

Apparatus Groups [ATEX and IECEx]

Group	Environment	Location	Typical Substance
I		Coal Mining	Methane (Fire damp)
IIA	Gases, Vapours	Surface and other locations	Acetic acid, Acetone, Ammonia, Butane, Cyclohexane, Gasoline (petrol), Kerosene, Methane (natural gas) (non-mining), Methanol (methyl alcohol), Propane, Propan-2-ol (iso-propyl alcohol), Toluene, Xylene
IIB			Di-ethyl ether, Ethylene, Methyl ethyl ketone (MEK), Propan-1-ol (n-propyl alcohol), Ethanol (ethyl alcohol)
IIC			Acetylene, Hydrogen, Carbon disulphide
IIIA	Combustible Dusts	Surface and other locations	Combustible flyings
IIIB			Non-conductive
IIIC			Conductive

Apparatus Groups (US / CAN)

Substance	Hazard Class	NEC 500	NEC 505
Acetylene	Class I Flammable Gases	Group A	IIC
Hydrogen		Group B	IIC
Ethylene		Group C	IIB
Propane		Group D	IIA
Methane (mining)		Group D	-
Combustible Metal Dusts	Class II Combustible Dusts	Group E	-
Combustible Carbonaceous Dusts		Group F	-
Combustible Dusts not in Group E or F (Flour, Grain, Wood, Plastics, Chemicals)		Group G	-
Combustible Fibres and Flyings		Class III Fibres and Flyings	-

Classification of Divisions and Zones

Type of Area	NEC and CEC*	ATEX and IEC	Definitions
Continuous hazard	Division 1	Zone 0 / Zone 20 Cat 1	A place in which an explosive atmosphere is continuously present
Intermittent hazard	Division 1	Zone 1 / Zone 21 Cat 2	A place in which an explosive atmosphere is likely to occur in normal operation
Hazard under abnormal conditions	Division 2	Zone 2 / Zone 22 Cat 3	A place in which an explosive atmosphere is not likely to occur in normal operation, but may occur for short periods

* On occasion the ATEX and IEC Zones may be used in the corresponding NEC and CEC system

Temperature Classification

Classification of maximum surface temperatures for Group II Electronic Equipment (T Class).

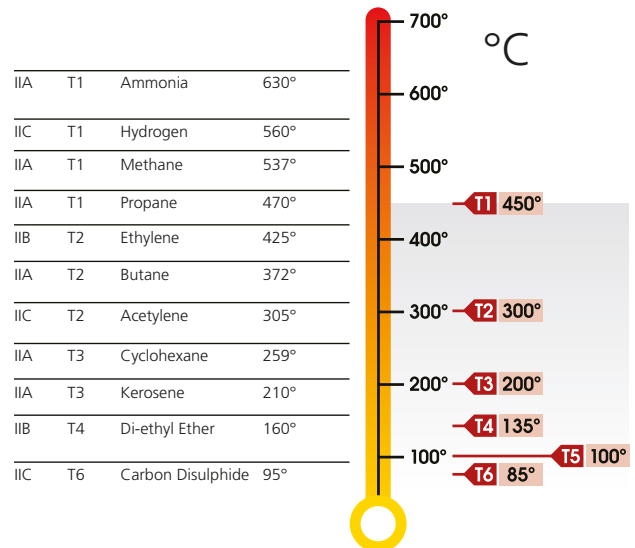

Dusts Typical Ignition Temperatures (°C)

Dusts	Cloud	Layer
Aluminium	590 °C	>450 °C
Coal dust (lignite)	380 °C	225 °C
Flour	490 °C	340 °C
Grain dust	510 °C	300 °C
Methyl cellulose	420 °C	320 °C
Phenolic resin	530 °C	>450 °C (melts)
Polythene	420 °C	>450 °C
PVC	700 °C	>450 °C
Soot	810 °C	570 °C
Starch	460 °C	435 °C
Sugar	490 °C	460 °C

Ingress Protection Codes

First Number (protect from solid bodies)		Second Number (protect from water)	
0	No protection	0	No protection
1	Objects > 50mm	1	Vertical drip
2	Objects > 12.5mm	2	Angled drip
3	Objects > 2.5mm	3	Spraying
4	Objects > 1.0mm	4	Splashing
5	Dust-protected	5	Jetting
6	Dust-tight	6	Powerful jetting
		7	Temporary immersion
		8	Continuous immersion

Enclosure Type Ratings (NEMA / CSA / UL)

Type	Area	Brief Definition
1	Indoor	General purpose
2	Indoor	Protection against angled dripping water
3, 3R, 3S	Indoor / Outdoor	Protection against rain, snow
4, 4X	Indoor / Outdoor	Protection against rain, snow, hose directed water
5	Indoor	Protection against angled dripping water, dust, fibres, flyings
6	Indoor / Outdoor	Protection against temporary submersion
6P	Indoor / Outdoor	Protection against prolonged submersion
12, 12K	Indoor	Protection against circulating dust, fibres, flyings
13	Indoor	Protection against circulating dust, fibres, flyings, seepage

Appendix B: Certifications

Product	Model Number	Cert. Type	Rating		
Electro-Pneumatic Positioner	YT-1000 / 1050	ATEX, UKEX	II 2G Ex db mb IIB T5 Gb		
		IECEX/CCOE	Ex db mb IIB T5 Gb		
		EAC	1Ex d mb IIB T5 Gb X IP66		
		INMETRO	Ex db mb IIB T5 Gb		
	YT-1000	FM	XP-S/I/1/CD/T5 Ta=60°C; DIP/II,III/1/EFG/T5 Ta=60°C; Type 4X		
		CSA	(Class I, Zone 1) Ex dm IIB T5		
		CCC	Ex d mb IIB T5 Gb:CCC, Ex d mb IIC T6 Gb:CCC, Ex ia IIC T6 Gb:CCC		
		TIIS	Ex dmb IIB T5		
		TS	Ex db mb IIB T5 Gb X		
		KCs	Ex dmb IIB T5/T4		
			Ex d IIC T5 IP66		
	YT-1050	ATEX/IECEX/KCs/CCC	Ex ia IIB T6 Gb		
	Smart Positioner	YT-3300 / 3350 / 3301 / 3303 / 3400 / 3450 / 3700 / 3750	KCs	Ex dmb IIB T5	
		YT-3300 / 3350	YT-3300 / 3350	SIL	SIL2 / SIL3
			CCOE/NEPSI	Ex ia IIC T5/T6 Gb	
ATEX			Ex ia IIC T5/T6 Gb, Ex ia IIIC T100°C/T85°C Db IP66		
IECEX			Ex ia IIC T5/T6 Gb, Ex ia IIIC T100°C/T85°C Db IP66		
YT-3300 / 3350 / 3301 / 3303		EAC	1Ex ia IIC T6...T5 Gb X, Ex ia IIIC T85°C...T100°C Db X 0Ex ia IIC T6...T5 Ga X, Ex ia IIIC T85°C...T100°C Da X IP66		
		INMETRO	Ex ia IIC T6/T5 Gb		
			Ex ia IIIC T85°C/T100°C Db IP66		
		FM	Class I, Div 1, Groups ABCD; Class I, Zone 0 AEx ia IIC; Class II/III, Div 1, Groups EFG; Class I, II, III, Div 2, Groups ABCDEFG; Type 4X/IP66 or IP54, T5 -40°C to 60°C, T6 -40°C to 40°C		
		CSA	Class I, Division 1/2, Groups ABC and/or D T5/T6 Class II, Division 1/2, Groups EF and/or G T100°C/T85°C; Class III Ex ia IIC T5/T6 Gb; Ex tb IIIC T100°C/T85°C Db		
		CCC	Ex ia IIC T5/T6 Gb, Ex iaD 21 T100/T85		
		KCs	Ex ia IIC T5/T6 Gb, Ex iaD IIIC T100°C/T85°C		
		ATEX	Ex db IIC T5/T6, Ex tb IIIC T100°C/T85°C		
		IECEX	Ex db IIC T5/T6, Ex tb IIIC T100°C/T85°C		
		YT-3400 / 3450	FM	Class I Div 1, Groups ABCD; T6 Ta = -40°C to +70°C, T5 Ta= -40°C to +80°C; Type 4X/IP66 Class II, III Div 1, Groups EFG; T6 Ta = -40°C to +70°C, T5 Ta= -40°C to +80°C; Type 4X/IP66 Class I, Zone 1, AEx db IIC T6 Ta = -40°C to +70°C, T5 Ta= -40°C to +80°C; Type 4X/IP66 Zone 21/Aex tb/IIIC/T85°C Ta= -40°C to +70°C, T100°C Ta= -40°C to +80°C; Type 4X/IP66	
	CSA		Ex db IIC Gb T5 or T6; Class I, Div 1, Groups CD; Class II, Div 1, Groups EFG; Type 4X /IP66 Ex tb IIIC Db T85°C/T100°C		
CCC	Ex d IIC T5/T6 Gb, Ex tD A21 IP66 T85°C/T100°C				
EAC	1Ex d IIC T6...T5 Gb X Ex tb IIIC T85°C...T100°C Db X IP66				
NEPSI	Ex d IIC T5/T6 Gb, Ex tD A21 IP66 T85°C/T100°C				
CCOE/ INMETRO	Ex db IIC T5/T6 Gb IP66 Ex tb IIIC T100°C/T85°C Db IP66				
YT-3400	KCs		Ex d IIC T5/T6 IP66		
YT-3450	KCs		Ex d IIC T5/T6, Ex tb IIIC T100°C/T85°C		
YT-2500	EAC		1Ex ia IIC T6...T5 Gb X Ex ia IIIC T85°C...T100°C Db X IP66		
	NEPSI		Ex ia IIC T5/T6 Gb		
		Ex iaD 21 T100/T85			



Appendix B: Certifications

Product	Model Number	Cert. Type	Rating	
Smart Positioner	YT-2500 / 2550 / 2501	ATEX	Ex ia IIC T5/T6 Gb, Ex ia IIIC T100°C/T85°C IP6X	
		IECEX	Ex ia IIC T5/T6 Gb, Ex ia IIIC T100°C/T85°C IP6X	
		CCC	Ex ia IIC T5/T6 Gb, Ex iaD 21 T100/T85	
		KCs	Ex ia IIC T5/T6, Ex iaD IIIC T100°C/T85°C	
	YT-2600	ATEX	Ex db IIC T5/T6, Ex tb IIIC T100°C/T85°C	
		IECEX	Ex db IIC T5/T6, Ex tb IIIC T100°C/T85°C	
		KCs	Ex d IIC T5/T6 IP66	
		CCC	Ex d IIC T5/T6 Gb, Ex tD A21 IP66 T85°C/T100°C	
		EAC	1Ex d IIC T6...T5 Gb X Ex tb IIIC T85°C...T100°C Db X IP66	
		ATEX	Ex ia IIC T5/T6 Gb, Ex ia IIIC T100°C/T85°C Db IP 6x	
	YT-3700 / 3750	IECEX	Ex ia IIC T5/T6 Gb, Ex ia IIIC T100°C/T85°C Db IP 6x	
		CCC	Ex ia IIC T5/T6 Gb, Ex iaD 21 T100/T85	
		KCs	Ex ia IIC T6/T5, Ex ia IIIC T85°C/T100°C	
		FM	Class I, Div 1, Groups ABCD; Class I, Zone 0 AEx ia IIC; Class II/III, Div 1, Groups EFG; Class I, II, III, Div 2, Groups ABCDEFG, Zone 21 AEx tb IIIC T100°C...T85°C, NEMA Type 4X IP66 or IP54, AMBIENT TEMP: -40°C to +60°C (T5) / -40°C to +40°C (T6)	
		CSA	Ex ia IIC T6/T5 Gb; Ex ia IIIC T85°C/T100°C Db, Class I, Division 1 and Division 2, Groups A, B, C, D T6/T5, Class II, Division 1 and Division 2, Groups E, F, G, T85°C/T100°C, Class III.	
		INMETRO	Ex ia IIC T6/T5 Gb, Ex ia IIC T85°C/T100°C Db IP66 1Ex ia IIC T6...T5 Gb X / Ex ia IIIC T85°C...T100°C Db X	
		EAC	0Ex ia IIC T6...T5 Ga X / Ex ia IIIC T85°C...T100°C Da X IP66	
		CCOE/ECAS	Ex ia IIC T5/T6 Gb Ex ia IIIC T100°C/T85°C Db IP6X	
		YT-930	ATEX	Ex ia IIC T5/T6 Gb, Ex ia IIIC T100°C/T85°C Db
			IECEX	Ex ia IIC T5/T6 Gb, Ex ia IIIC T100°C/T85°C Db
	IP Converter	YT-940	FM	Class I Division 1, Groups A, B, C, D; T6 Ta= -40°C to +75°C, T5 Ta= -40°C to +85°C; Type4X, IP66 Class II, III Division 1, Groups E, F, G; T6 Ta= -40°C to +75°C, T5 Ta= -40°C to +85°C; Type4X, IP66 Class I, Zone 1, AEx d IIC T6 Ta= -40°C to +75°C, T5 Ta= -40°C to +85°C, Type 4X, IP66 Zone 21 AEx tb IIC T85°C Ta= -40°C to +75°C, T100°C Ta= -40°C to 85°C, Type 4X, IP66
CSA			Ex db IIC T5 or T6 Ex tb IIC T85°C/T100°C, IP66	
KCs			Ex d IIC T5/T6	
YT-720		KCs	Ex d IIC T6	
		EAC	1Ex d IIC T6 Gb IP66	
Solenoid Valve	YT-720	CCC	Ex d IIC T6 Gb	
		KCs	Ex ia IIC T5	
	SPTM-5V	EAC	1Ex ia IIC T5 Gb IP67	
		NEPSI	Ex ia IIC T5 Gb	
		KCs	Ex d IIC T6 IP67	
SPTM-6V / 65V	EAC	1Ex d IIC T6 Gb IP67		
	NEPSI	Ex d IIC T6 Gb		
	ATEX	Ex db IIC T6, Ex tb IIIC T85°C		
Limit Switch	YT-870 / 875	IECEX	Ex db IIC T6, Ex tb IIIC T85°C Ex db IIC T6 Class I, Zone 1, AEx db IIC T6 Class II, Division 1, Groups: E, F and G, Ex tb IIC T85°C Zone 21, AEx tb IIC T85°C	
		CCC	Ex d IIC T6 Gb Ex tD A21 IP67 T85°C	
		KCs	Ex d IIC T6	
	Volume Booster	YT-300 / 305 / 320 / 325 / 310 / 315	SIL	SIL2 / SIL3

Site Services

Rotork understand the value of prompt, punctual and superior site services. Rotork Site Services have specialist expertise, insight and experience in service support for mission-critical flow control and instrumentation solutions for oil and gas, water and wastewater, power, chemical process and industrial applications. We offer global frontline support backed by dedicated in-house experts.

Our service solutions increase plant efficiency and reduce maintenance costs, while workshop services return equipment to as-new condition. Our experience and understanding of the flow control industry means we have extensive insight and ideas of what we can do to provide significant value to our customers and their operations.

Rotork Site Services is comprised of two main areas; Lifetime Management and Site Services. Lifetime Management is the suite of services within Rotork Site Services which help you manage the risk associated with aging assets and includes our Reliability Services offering. Site Services comprises essential actuator service, repair, maintenance and upgrades.

Rotork has specialist expertise, insight and experience in flow control.

We provide insight into how we can deliver value to our customers.

Our service solutions increase plant efficiency and reduce maintenance costs.



Site Services

Lifetime Management

The services available within Lifetime Management offer a complete solution to managing the risks associated with the life cycle of your equipment and their obsolescence (which compromise reliable performance and valuable uptime).

The aim of Lifetime Management is to provide you with constant support and minimum- to- no disruption to your production flow. It is a customisable service offering designed to seamlessly maintain and improve your assets. We manage the inherent risks associated with advances in technology, component obsolescence and ageing equipment for you. We are committed to helping customers maximise the continuous, fault-free operation and working life of their actuators. Supporting the continuous and reliable operation of your plant allows for improved performance and increases in valuable uptime.

Lifetime Management covers:

- Reliability Services
 - Basic - Health Check
 - Standard - Planned Maintenance
 - Premium - Enhanced Maintenance
- Upgrade services (retrofit)
- Planned shutdown support
- Life cycle services
- Overhauls/refurbishment
- Customised spares programme
- Intelligent Asset Management reporting

Site Services

Rotork's Site Services comprises the essential on-site actuator service, repair, maintenance and upgrades part of our service offering, plus the commissioning of new actuators and applications. It includes off-site work completed at a Rotork Support Centre including recertification, automation, testing and product selection.

Our decades of experience in the industrial actuation and flow control markets means that customers can rely on us to understand their problems and to deliver reliable, economic solutions. Rotork's talented and experienced engineers have an in-depth understanding of the problems that are faced in the field and they know how to fix them.

On sites where providing evidence of valid asset certification is a legal requirement, Rotork engineers can carry out the necessary OEM level inspections and provide the statutory paperwork to comply with regulations.

- Planned Shutdown Support
- Actuator Workshop Overhaul
- Field Support
- Valve Automation Services
 - On-site
 - Off-site
- Global Support



rotork®



www.rotork.com

A full listing of our worldwide sales and service network is available on our website.

Rotork plc
Brassmill Lane, Bath, UK
tel +44 (0)1225 733200
email mail@rotork.com

Rotork
81, Hwanggeum-ro 89 beon-gil, Yangchon-eup,
Gimpo-si, Gyeonggi-do, South Korea, 10048
web www.ytc.co.kr
tel +82 31 986 8545
fax +82 70 4170 4927
email ytic.sales@rotork.com

PUB126-001-00
Issue 02/23

As part of a process of on-going product development, Rotork reserves the right to amend and change specifications without prior notice. Published data may be subject to change. For the very latest version release, visit our website at www.rotork.com

The name Rotork is a registered trademark. Rotork recognises all registered trademarks. Published and produced in the UK by Rotork. POLTG0223